



ITT

BPHV

Commercial Water

Goulds Pumps

PHV – Packaged Hydrovar Series

Variable Speed Water Booster with
Vertical Multistage Pump and
Fused Disconnect



Engineered for life



Goulds Pumps

PHV - Packaged Hydrovar Series

CONTENTS

Selection Chart **3**

Main Components..... **4**

Part Numbering **5**

Markets and Applications **6-8**

Hydrovar Specifications / Listings **9-11**

Multi-Pump Example..... **12**

Operation / Selecting..... **13**

Fused Disconnect **15**

Motor Data..... **17**

Variable Speed Curves **19-36**

Technical Data - Pump Hydraulics **37-40**

Dimensions / Weights **41-46**

Technical Data - References **48-49**

**PHV SERIES SELECTION CHART (PACKAGED HYDROVAR)
HYDRAULIC PERFORMANCE RANGE AT 60 Hz**

SSV Pump Model	Stage	HP	FLOW 0 GPM	5	7.5	10	12.5	15	17.5	20	25	30	35	40	45	50	55	60	65	70	75	80	85	90	95	100	105	110
				HEAD IN FEET																								
1SV	6	2	300	279	265	247	226	200	173	142																		
1SV	9	3	442	416	395	369	338	300	259	212																		
1SV	15	5	732	692	657	615	564	505	436	359																		
2SV	5	2	217	211	206	200	196	189	182	174	156	135	112	85														
2SV	8	3	353	340	331	325	315	304	292	279	249	215	178	136														
2SV	13	5	586	560	546	530	513	493	473	451	400	347	286	219														
2SV	16	7.5	710	687	671	654	634	611	585	559	496	426	344	254														
3SV	2	2	124			123		122		120	118	115	111	107	103	98	92	85	79	71	63							
3SV	4	5	245			245		244		241		237	231	217	208	197	186	173	159	143	128							
3SV	7	7.5	440			435		430		423	414	403	390	377	360	343	323	303	280	256	229							
3SV	9	10	565			559		552		544	530	518	503	484	464	441	415	388	358	326	292							
3SV	13	15	817			809		801		788	772	750	730	703	673	639	603	562	519	470	419							
4SV	2	5	149			149		149		149		148		146	145	143	141	139	136	133	130	126	123	118	114	109	105	99
4SV	4	7.5	300			300		300		300		300		295	291	286	283	277	272	265	258	250	242	233	223	213	203	191
4SV	7	15	530			530		530		530		523		518	512	504	497	487	478	465	451	439	423	407	388	371	352	332

SSV Pump Model	Stage	HP	FLOW 0 GPM	40	60	80	100	120	140	160	180	200	220	240	260	280	300	320
				HEAD IN FEET														
33SV	1/0	5	110	110	109	108	105	102	96	91	84	76	68					
33SV	2/2	7.5	163	163	161	157	152	144	135	124	112	97	81					
33SV	2/0	10	222	222	220	216	210	202	193	181	168	153	137					
33SV	3/0	15	334	334	330	323	314	302	288	272	253	231	206					
46SV	1/0	10	124	121	119	117	114	110	107	103	98	93	88	82	75	69	62	55
46SV	2/0	15	253	249	246	242	238	232	226	220	213	204	196	186	176	165	153	140

NOTE: Head in feet is boost pressure.

Goulds Pumps

PHV - Packaged Hydrovar Series



MAIN COMPONENTS

of **PHV Series** constant pressure variable speed system

- One multistage vertical **pump**, Goulds Pumps SSV series.
- **Hydrovar**® pump mounted variable speed drive
- **Pressure transducer** for constant pressure control, connected to the Hydrovar drive.
- **NEMA 4X** fused disconnect panel with corrosion resistant durable plastic; external on/off switch with lockout/tagout. Panel is bracket mounted directly to pump.
- **Electrical panel** for control and protection, with casing made of plastic material, NEMA 4X, equipped with:
 - fast acting fuses. The panel is mounted on the electric pump using a bracket.

The pump package comes pre-assembled and tested, complete with operating instructions and panel wiring diagram.

- 1) Vertical multi-stage stainless pump
- 2) TEFC standard NEMA 2-pole motor
- 3) NEMA 4X fused disconnect panel
- 4) ITT Hydrovar® variable speed controller
- 5) cUL flexible liquid tight conduit/wiring
- 6) Pressure transducer (sensor) with cable
- 7) Outdoor use

“QCZJ7 Packaged Pumping System”

PART NUMBERING / IDENTIFICATION CODES — PHV SERIES

PACKAGED HYDROVAR VARIABLE SPEED SSV PRODUCT LINE NUMBERING SYSTEM

The various versions of the PHV line are identified by a product code number on the pump label. The number is also the catalog number for the package. The meaning of each digit in the product code is shown below.

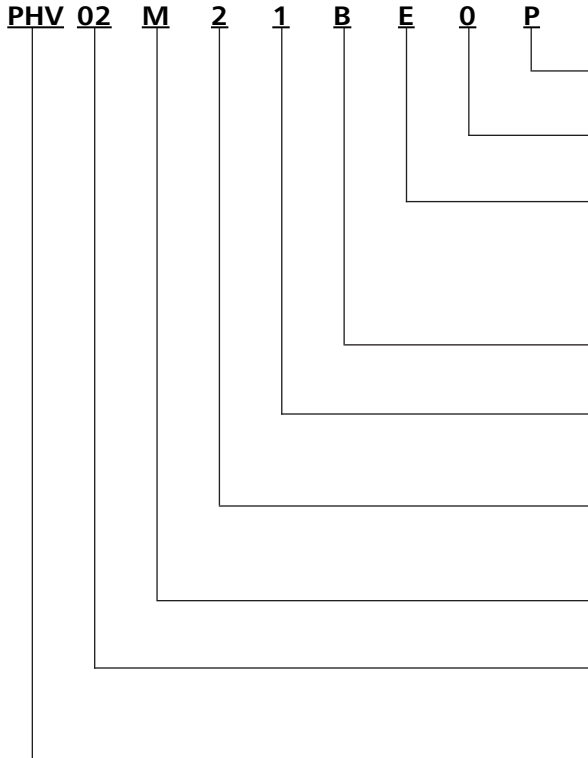

Option List in order shown:

P = Premium Efficiency F = Harmonic Filter T = 500 PSI Transducer

Reduced Stages (33-46SV Only) (can be 0, 1 or 2)*:

0 = 0 reduced 1 = 1 reduced 2 = 2 reduced

Number of Stages:

A = 1	E = 5	J = 9	N = 13	S = 17	Z = 24
B = 2	F = 6	K = 10	P = 14	T = 18	
C = 3	G = 7	L = 11	Q = 15	V = 20	
D = 4	H = 8	M = 12	R = 16	X = 22	

Flange Type:

A = NPT Oval B = ANSI D = 316SS ANSI

Pump Model:

1 = 1SV 2 = 2SV 3 = 3SV 4 = 4SV
5 = 33SV 6 = 46SV 7 = 66SV 8 = 92SV

Voltage:

2 = 230V
4 = 460V

Hydrovar Type:

M = Master Controller

HP Rating:

02 = 2 HP 03 = 3 HP 05 = 5 HP
07 = 7½ HP 10 = 10 HP 15 = 15 HP

PHV - Series (SSV & Hydrovar Package)

* **Notes:** Indicates number of reduced diameter impellers in the total staging. (2 would indicate 2 reduced diameter impellers.)

CAUTION: 500 PSI transducer measures accurately to 400 PSI. Pump, flanges and other piping system components must also be rated for the maximum system pressure. See SSV technical manual and other appropriate technical manuals to verify all equipment is rated to maximum system pressure.

Notes:

1. Not all combinations are available.
2. Standard motor is Baldor TEFC, 3 Phase, TC frame.
3. Standard Hydrovar VSD is master - capable of multi-control.
4. Fuse box contains class J or equal fast acting fuses.
5. Tank, piping and valves sold separately.
6. Includes 300 PSI transducer.

HYDROVAR VARIABLE SPEED CONTROLLERS

Hydrovar variable speed drives are identified by the following code. The meaning of each digit in the product code is shown below.

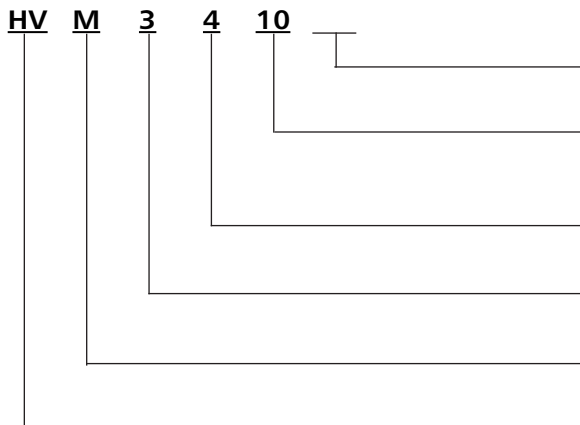

Filter (optional):

Standard = Blank Residential = B

HP Rating:

02 = 2 HP 03 = 3 HP 05 = 5 HP
07 = 7 HP 10 = 10 HP 15 = 15 HP

Voltage:

2 = 230V 4 = 460V

Phase:

1 = Single Phase 3 = Three Phase

Type:

M = Master S = Single B = Basic

HV - Series

Notes:

1. Not all combinations are available.
2. Includes drive, mounting hardware, 300 PSI transducer and conduit gland and plugs.

Goulds Pumps

PHV - Packaged Hydrovar Series

MARKETS AND APPLICATIONS

Booster Sets

MARKETS SERVED

MUNICIPAL, COMMERCIAL, INDUSTRIAL

APPLICATIONS

- Water network supply in condominiums, offices, hotels, shopping centers, factories, water treatment, process control.
- Water supply to agricultural water networks (e.g. irrigation).
- Variable flow / demand applications requiring constant pressure control.

PHV Series



SPECIFICATIONS

- **Flow rate** up to 320 GPM.
- **Head** up to 692' TDH.
- **Supply voltage:**
1Ø, 230V ± 10% up to 3 HP.
3Ø, 400V ± 10% for 3 HP – 15 HP.
- **Input Frequency:** 50 or 60 Hz.
- **External control voltage:**
0-5 VDC; 0-10 VDC; 0-20 mA.
- **Protection class**
 - panel: NEMA 4X.
 - drive: NEMA 4 up to 15 HP.
 - outdoor use.
- **Maximum HP:** 15 HP.
- **Soft motor start.**
- **Vertical design pump:**
 - SV..T series (motor insulation class, F, TEFC enclosure).
- **Maximum operating pressure:**
360 PSI for sets with SV..T electric pumps.
- **Maximum temperature of pumped liquid:** 180° F.

MARKETS AND APPLICATIONS *(continued)*

WATER SUPPLY AND PRESSURE BOOSTING

- Pressure boosting in buildings, hotels, residential complexes
- Pressure booster stations, supply of water networks
- Booster packages

WATER TREATMENT

- Ultrafiltration systems
- Reverse osmosis systems
- Water softeners and de-mineralization
- Distillation systems
- Filtration

LIGHT INDUSTRY

- Washing and cleaning plants (washing and degreasing of mechanical parts, car and truck wash tunnels, washing of electronic industry circuits)
- Commercial washers
- Firefighting system pumps

IRRIGATION AND AGRICULTURE

- Greenhouses
- Humidifiers
- Sprinkler irrigation

HEATING, VENTILATION AND AIR CONDITIONING (HVAC)

- Cooling towers and systems
- Temperature control systems
- Refrigerators
- Induction heating
- Heat exchangers
- Boilers
- Water recirculation and heating

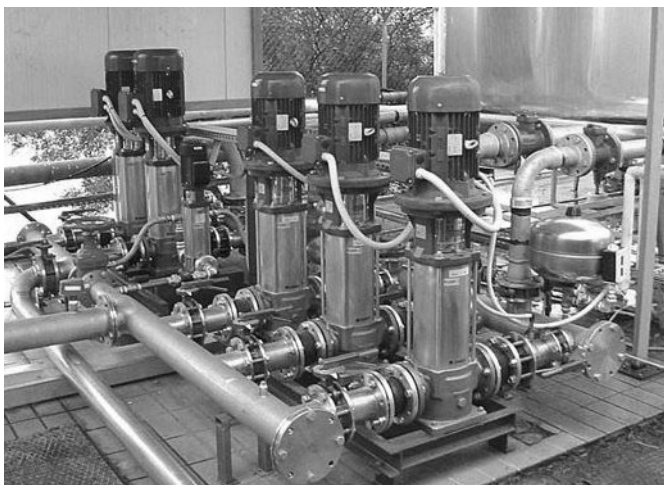
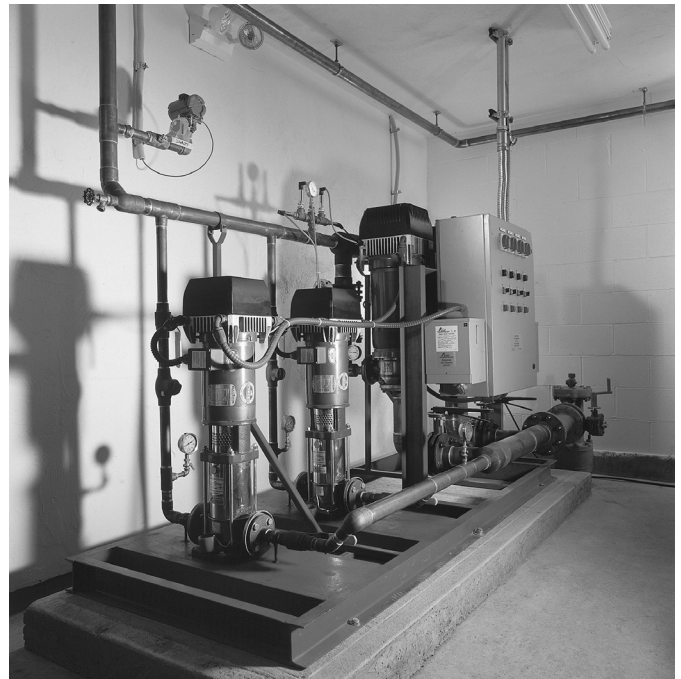

Goulds Pumps

PHV - Packaged Hydrovar Series

MARKETS AND APPLICATIONS

(continued)

MUNICIPAL, AGRICULTURAL, LIGHT INDUSTRY,
WATER TREATMENT, HEATING AND AIR CONDITIONING

APPLICATIONS

- Handling of water, free of suspended solids, in the municipal, industrial and agricultural markets
- Pressure boosting and water supply systems
- Fire fighting jockey pumps
- Irrigation systems
- Wash systems
- Water treatment plants: reverse osmosis
- Handling of moderately aggressive liquids, demineralized water, water and glycol, etc.
- Circulation of hot and cold water for heating, cooling and conditioning systems
- Boiler feed

SPECIFICATIONS

PUMP

The SSV pump is a non-self priming vertical multistage pump coupled to a standard motor. The liquid end, located between the upper cover and the pump casing, is held in place by tie rods. The pump casing is available with different configurations and connection types.

- Delivery: up to 600 GPM
- Head: up to 1200 feet
- Temperature of pumped liquid: -20°F to 250°F (-30°C to 120°C) standard version
- Maximum operating pressure
 - with oval flanges: 230 PSI (15 bar)
 - with round flanges or Victaulic: 360 PSI (25 bar)
 - SV33, 46: 230, 360 or 575 PSI (16, 25 or 40 bar)*
 - SV 66, 92: 230 or 360 PSI (16 or 25 bar)*
- Direction of rotation: clockwise looking at the pump from the top down (marked with an arrow on the adapter and on the coupling).

MOTOR

- Standard NEMA TC Frame motors totally enclosed fan cooled.
- Efficiency is 75.5% or higher, Class "F" insulation
- 3500 RPM nominal
- Standard voltage:
 - Single phase version: 115-208/230 V, 60 Hz up to 3 HP or 208-230 V for 5 HP
 - Three phase version, 2 pole: 208-230/460 V, 60 Hz up to 75 HP

* Based on pump staging

MAIN CHARACTERISTICS OF FREQUENCY CONVERTERS USED IN THE PHV BOOSTER SETS

The PHV series booster sets use a **Hydrovar®** variable frequency drive, an automatic device that adjusts the speed of the electric pump in order to maintain **constant pressure** in the system.

Converters with power up to 30 HP can be **mounted directly on to the motor**. Models with over 30 HP power, are designed for wall mounting only. The pressure is measured by a **pressure transmitter** which uses a standard **4..20 mA** current signal. The system pressure value can be read on the converter's display. A simple user interface allows you to set the desired pressure value for optimal adjustment, as well as to **view the operating data**, such as the hours of operation and any alarms triggered. Included diagnostic menu to view temperature, current and voltage values facilitates diagnostics and failure analysis. Indicator lights signal power status, pump running and malfunctions.

A **password** is required to access sensitive settings that allow you to **program the Hydrovar** in order to adapt it to any control requirements, such as **flow resistance compensation, external control**, periodic testing and so on. When more than one pump is used, the converters exchange information with each other through an **RS485 serial line** which can connect up to 8 Hydrovar devices plus one external unit for remote control. The Pump-link and Pump-watcher dedicated systems, connected to the Hydrovar®, enable remote control through a traditional telephone line or mobile telephony. A serial port available as standard up to 15 HP allows you to control the Hydrovar® converters from a Modbus® field serial bus line.

The converter is equipped with two **potential-free relays** which can be used for **remote signalling** of pump running and malfunction status, plus a programmable voltage **analogue output** for signalling the frequency or pressure. Standard version with two sensor inputs for implementing of two actual values signals within one system (min/max, difference) or for a second sensor for safety reasons. Specific digital **inputs** are used for protection against **water failure, motor overtemperature**, as well as for external enable signal and remote control. The converter also incorporates a dry running protection function via an adjustable **minimum pressure** threshold.

FCC Class A filter standard for Hydrovar three-phase power supply. E.g. Industrial areas, technical areas of any building fed from a dedicated transformer are examples of environment locations.

FCC Class B filter standard for Hydrovar single-phase power supply.

E.g. Houses, apartments, commercial premises or offices in a residential building are examples of environment locations.

Further information is available in the Hydrovar manual.



Modular Hydrovar, Bare Unit



PHV Series Hydrovar with SSV Pump

Goulds Pumps

PHV - Packaged Hydrovar Series

CHARACTERISTICS OF THE ELECTRIC PUMPS USED IN PHV SERIES BOOSTER PACKAGE

1, 2, 3 AND 4 SSV VERTICAL MULTI-STAGE PUMPS

- Multistage centrifugal vertical electric pumps. All metal parts in contact with pumped liquid are made of 304/316 stainless steel.
- A version: round flanges, in-line discharge and suction ports, AISI 304
- B version: ANSI flanges, in-line discharge and suction ports, AISI 316
- Reduced axial thrusts enable the use of **standard motors** that are easily found on the market.
- Standard Baldor, NEMA motors
- Easy maintenance. No special tools required for assembly or disassembly.
- **ANSI/NSF 61 certified by CSA for potable drinking water.**

SV33 AND 46 MULTI-STAGE PUMPS

- Vertical multistage centrifugal pump with impellers, diffusers and outer sleeve made entirely of stainless steel, and with pump casing and upper head made of cast iron in the standard version.
- High hydraulic efficiency for significant energy savings.
- Innovative axial load compensation system on pumps with higher head. This ensures reduced axial thrusts and enables the use of standard motors that are easily found on the market.
- Standard NEMA Baldor® motors.
- Mechanical seal can easily be replaced without disassembling the motor from the pump.
- Mechanical sturdiness and easy maintenance. No special tools required for assembly or disassembly.
- **ANSI/NSF 61 certified by CSA for potable drinking water.**

REFERENCE STANDARDS

- cUL Listed as pumping packaged unit, 42UC
- VFD (Hydrovar) UL recognized
- Baldor motor UL recognized
- Pumps meet ANSI/NSF 61 certification by CSA for potable drinking water
- Pumps meet ANSI/UL778 standards
- Control/disconnect meet UL508A standards

HYDROVAR VERSIONS

INTRODUCTION

The **HYDROVAR Concept** consists mechanically of two main parts, the **Power Unit** and the **Control Card**. In its basic configuration (consists only of the Power Unit) the HYDROVAR can be used as a **“Basic Inverter”** without the need of the Control Card. In that form the HYDROVAR can be used as a sequence pump in a multi pump system, with at least one master inverter.

By extending this “Basic Inverter” with the additional Control Card and LCD display, the HYDROVAR **“Master Unit”** is able to work in different modes and can be extended by the implementation of different modules.

STANDARD OPTIONAL FEATURES VERSIONS

CASCADE SERIAL (MASTER + BASIC)

In this mode there are various possibilities to combine the different versions of the HYDROVAR.

In general, each of the pumps is equipped with a HYDROVAR unit. Each pump of the system (extended up to 8 pumps) is equipped with a HYDROVAR unit (at least one **“Master Inverter”** and the others can be **“Basic Inverters”** in order to ensure a proper control of the system) which are connected via the serial interface.

Minimum requirement: One “Master Inverter” and the others equipped with “Basic Inverters”.

The whole control is performed via the “Master Inverter” every time, but also an automatic change over of the lag pumps to achieve even operating hours is possible.

Following versions are available:

- **Power size 3 HP up to 15 HP motor mounted single phase and/or three phase power supply.**
 - **PHV**: one pump with wiring, fused disconnect, master Hydrovar drive, transducer, conduit.

Goulds Pumps

PHV - Packaged Hydrovar Series

APPLICATION EXAMPLE – MULTI-PUMP “CASCADE”

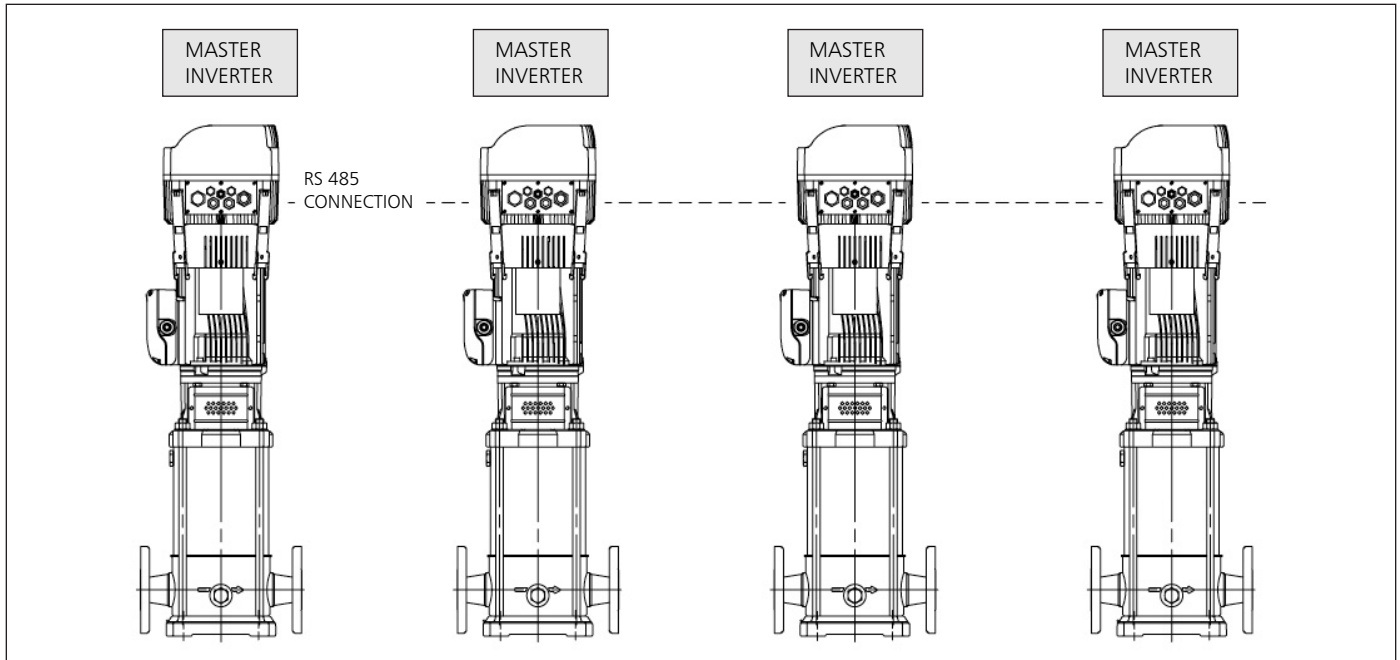

With the “master” version of the Hydrovar, it is possible to connect up to 8 Hydrovar controller pumps together in parallel. Complete lead/lag and auto alternation.

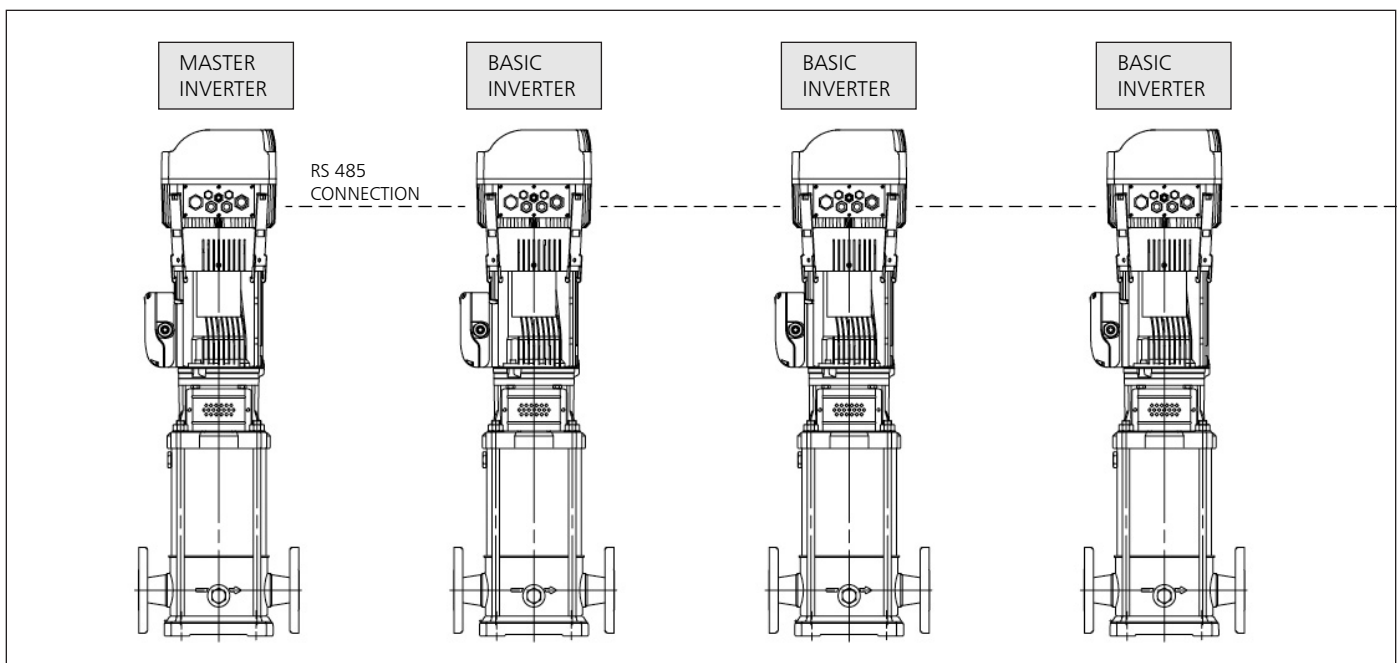

Reduction of overall cost for multi-pump system is possible using one “master” controller and several “basic” controllers. The Hydrovar “master” will still control lead/lag, alternation.

OPERATION DESCRIPTION

SETS WITH VARIABLE-SPEED MOTORS AND PRESSURE TRANSDUCER CONTROL

The starting and stopping of the pumps are determined based on the pressure values set on the controller.

Each frequency converter is connected to a pressure transducer.

The controllers exchange information with each other and provide for cyclic changeover.

The figure shows the operating mode of a two-pump booster set (Typical Field Set).

- On demand, water is drawn from the tank.
- When the pressure drops below the PS setting the first pump starts and the speed is adjusted to maintain a constant pressure as demand increases.
- If the water consumption increases and the pump reaches maximum speed, the second pump starts and the speed is adjusted to maintain constant pressure.
- When demand decreases, the speed is reduced until minimum speed is reached and one of the pumps are switched off.
- If consumption keeps decreasing the pump slows down, fills the tank and stops at the pressure setting.

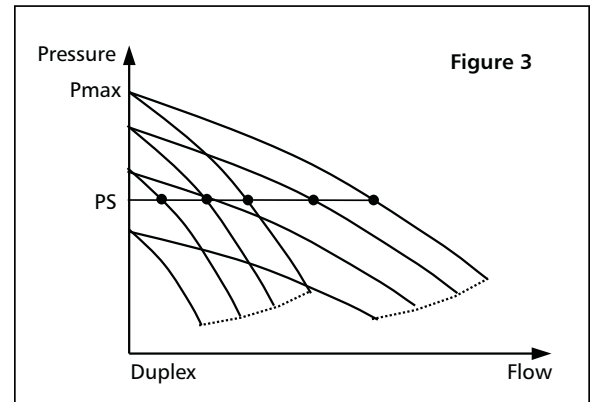

OPERATING CHARACTERISTICS AND LIMITS

Type of pumped liquids	Water containing no gas or corrosive and/or aggressive substances
Fluid temperature	Above 0° F to 180° F, Pressure transducer limited
Ambient temperature	Above 0° F to 104° F, VFD/Display, keep away from direct sun
Maximum operating pressure	360 PSI (Pump without transducer)
Minimum inlet pressure	According to NPSH curve and losses, with a minimum margin of 0.5 m
Maximum inlet pressure	The inlet pressure added to the pressure of the pump at zero flow must be lower than the maximum operating pressure of the set (suction and discharge).
Installation	Indoors/outdoors, protected from the direct sun. Away from heat sources. Maximum elevation 3300 feet ASL. Maximum humidity 50% without condensation.
Hourly starts	Maximum 60 up to 10 HP. Above 10 HP and up to 50 HP, maximum 40 starts per hour. Variable speed drive starts.
Sound emission	See table

* **Note:** For higher temperature it is necessary to use special materials (only on request).

NOISE EMISSION LEVELS

60 Hz 3500 RPM		LpA (dB ±4)
HP	NEMA Motor Frame	PHV
1	56	< 70
2	56	< 70
3	56	< 70
5	145	< 70
7½	182-184	< 70
10	215	< 70
15	254	73
20	256	75
25	284	75
30	284	75

* **Note:** Adjusted from 50 Hz data, may vary.

Goulds Pumps

PHV - Packaged Hydrovar Series

SELECTING A SET

The first thing to do when selecting a package is to determine the quantity of water required and the pressure it must supply.

CALCULATING THE FLOW RATE

- The quantity of water called **water requirement** depends on the type of users, e.g. homes, offices, schools, as well as their number. The theoretic requirement is the total amount of water required by all the users. In actual fact, since it is very unlikely that there should be a simultaneous demand by all the users, the **real requirement** is lower than the theoretic one.

CALCULATING THE HEAD

- The pressure required depends on the type of user. A number of factors must be taken into account, including the **height of the building**, the suction conditions and the flow resistance in the pipes.

SELECTING A BOOSTER SET

- According to the required flow rate and head values, it is possible to identify the most suitable type of electric pump. On two-pump sets the pumps normally act as **back-up for one another**. A single pump is normally sufficient to provide for average requirements, while in conditions of high demand the back up pump may be called in to assist. With the **cyclic changeover** function duty assignment is rotated to ensure both pumps remain active and with even running hours, so wear is uniform and the use factor is reduced for longer pump life. This system also ensures **continuity of operation** in case one of the pumps needs maintenance. The Hydrovar provides automatic lead/lag, alternation when programmed in multi-control and wired via RS485 communication terminals.

TANK

- Frequent demand or **small system losses** determine pressure variations that may be compensated for by using a **tank**. Correct selection of a diaphragm tank **reduces the number of pump starts** and, if it is installed near the booster set, helps reduce the effect of water hammer, or fast acting flush valves.

The booster sets are **ready** for installation of diaphragm tanks directly on the delivery manifold, and additional tanks can be connected to the unused end of the manifold.

For peak performance, variable speed booster sets need **smaller tanks** compared to traditional systems. Generally speaking, a tank with a capacity of just 20% of the nominal capacity of a single pump, expressed in gallons per minute, is required. Example: If my pump is sized for 100 GPM, then we would size a 20 gallon (total capacity) diaphragm tank.

- Pre-charge the tank with air, 10-15 PSI below your system pressure. Charge dry tank without water pressure or before installing in system.

FUSED DISCONNECT BOX:

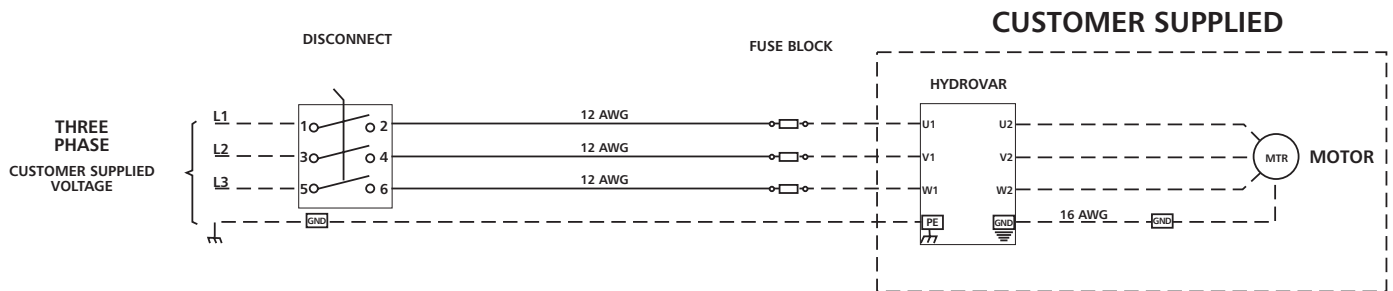
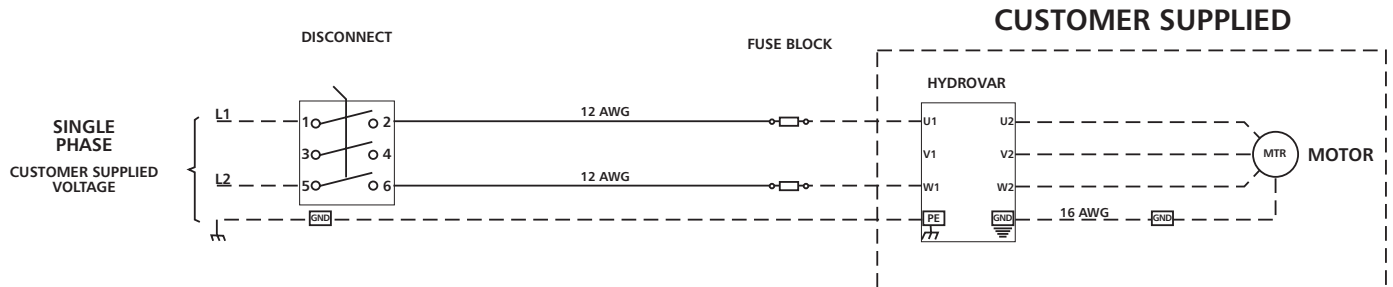

ITT Disconnect Part Number	Input Voltage	Disconnect	HP / AMP Rating	Wire Range	Tightening Torque	Fuse Supplier	AMP Rating	Part Number	Voltage Rating
HFD512C1	230/1/60	OT25F3	2 HP / 25A	#18-8AWG	7 IN/LB	Bussman	20	KTK-R-20	600V
HFD512E1	230/1/60	OT40F3	3 HP / 40A	#18-8AWG	7 IN/LB	Bussman	30	KTK-R-30	600V
HFD534A1	460/3/60	OT16F3	3 HP / 16A	#18-8AWG	7 IN/LB	Bussman	10	KTK-R-10	600V
HFD534B1	460/3/60	OT16F3	3 HP / 16A	#18-8AWG	7 IN/LB	Bussman	15	KTK-R-15	600V
HFD534C1	460/3/60	OT25F3	3 HP / 25A	#18-8AWG	7 IN/LB	Bussman	20	KTK-R-20	600V
HFD534C2	460/3/60	OT25F3	3 HP / 25A	#18-8AWG	7 IN/LB	Bussman	20	KTK-R-20	600V
HFD534E2	460/3/60	OT40F3	3 HP / 40A	#18-8AWG	7 IN/LB	Bussman	30	KTK-R-30	600V

NOTE: Recommended protection (not included with drive only). This fused disconnect is available as part of the PHV series packaged Hydrovar, see price book.

Goulds Pumps

PHV - Packaged Hydrovar Series

SPECIFICATIONS

Hydrovar VFD					Motor	
HP	Model *	Power Supply (V)	NEMA Class	Install.	Power Supply (V)	HP
2	HVM1202	1x230	4	TEFC Motor	3x230	2
3	HVM1203	1x230	4	TEFC Motor	3x230	3
3	HVM3403	3x460	4	TEFC Motor	3x460	3
5	HVM3405	3x460	4	TEFC Motor	3x460	5
7½	HVM3407	3x460	4	TEFC Motor	3x460	7½
10	HVM3410	3x460	4	TEFC Motor	3x460	10
15	HVM3415	3x460	4	TEFC Motor	3x460	15

* The new Hydrovar is available single-phase up to 3 HP and 3 HP through 15 HP, 460 volt.

ELECTRICAL PANELS - PHV (Packaged Hydrovar® Series)

The GHV sets come with a **fused disconnect** on which are installed automatic **line protection fast acting fuses** for each drive. Class J, 600 volt.

Single-pump sets are supplied as standard with an electrical panel encased in NEMA 4X enclosure, with 2-pole or 3-pole (3 phase) up to 30 amps and featuring a **main switch**.

The fused disconnect is rated for UL508A.

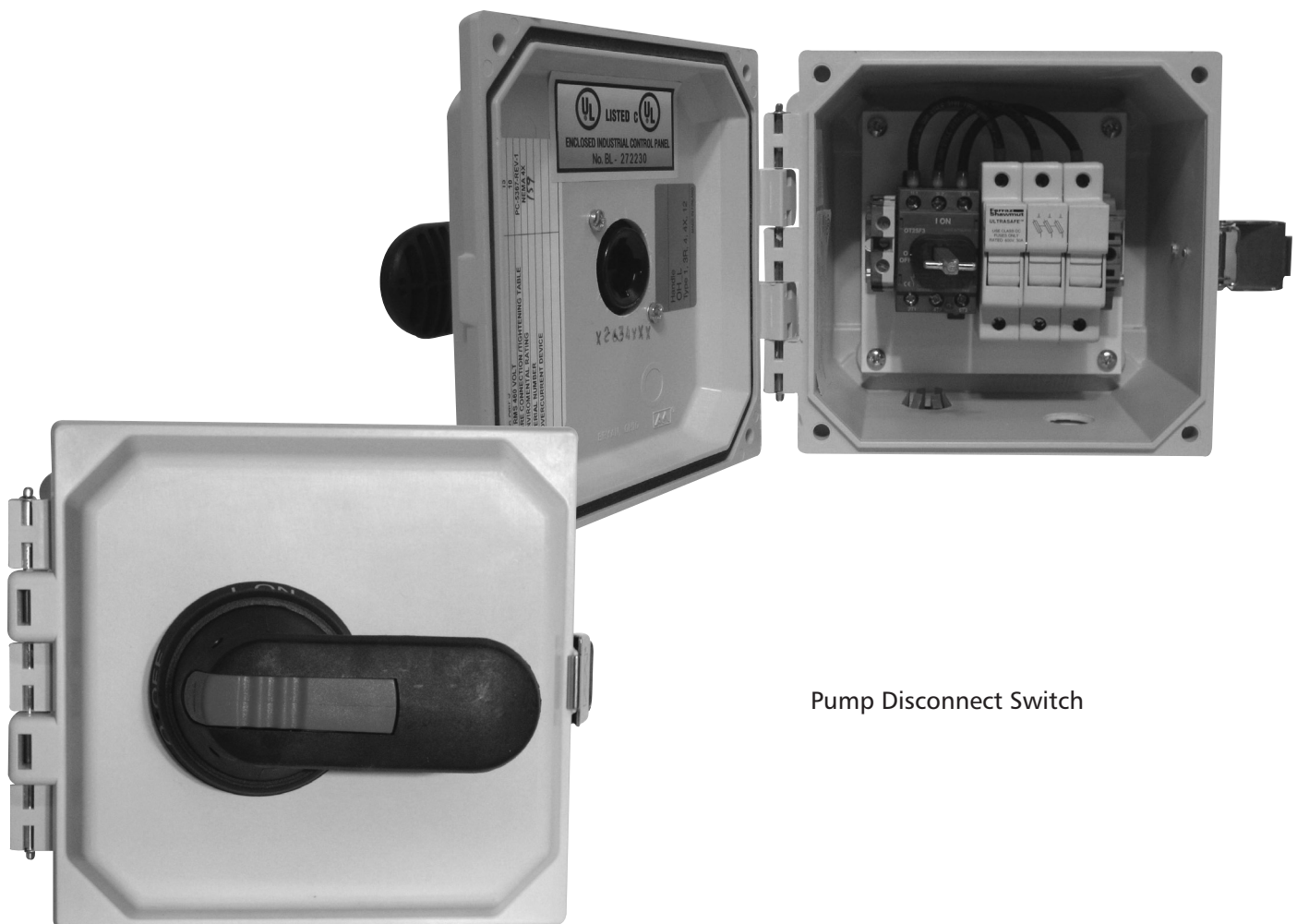

Pump Disconnect Switch

MOTOR DATA

3500 RPM, 60 Hz

HP	Phase	Enclosure	Nameplate Voltage	NEMA Frame	Goulds PN	FLA	SFA	LRA ①	S.F.	Efficiency	Insulation Class
1	3	TEFC	230/460	56C	V06742	3.7-3.6/1.8	3.99-3.8/1.9	11	1.25	75.5	B
		Prem. Eff. TEFC	230/460	56C	V06742PE	2.8/1.4	3.12/1.56	12.1	1.25	84.5	B
1½	3	TEFC	230/460	56C	V07742	4.9-4.6/2.3	5.3-5.1/2.54	18.4	1.15	80	B
		Prem. Eff. TEFC	230/460	56C	V07742PE	4.0/2.0	4.5/2.25	20.1	1.15	85.5	B
2*	3	TEFC	208-230/460	56C	V08742	6.2-5.8/2.9	7.2-6.52/3.26	22	1.15	80	B
		Prem. Eff. TEFC	208-230/460	56C	V08742PE	5/4.75-2.5	6.4-5.8/2.9	30	1.15	86.5	B
3*	3	TEFC	208-230/460	56C	V09742	8.1-7.6/3.8	9.5-8.6/4.3	32.9	1.15	82.5	F
		Prem. Eff. TEFC	208-230/460	184TC	V09742PE	6.8/3.4	8.5-7.7/3.8	32	1.15	88.5	F
5*	3	TEFC	208-230/460	184TC	V10742A	13.2-12/6	15-13.6/6.8	47	1.15	85.5	F
		Prem. Eff. TEFC	208-230/460	184TC	V10742APE	11.2/5.7	14.4-13/6.5	55	1.15	90.2	F
7½*	3	TEFC	208-230/460	184TC	V11742A	18.5/17.4	21.7-19.6/9.8	94	1.15	88.5	F
		Prem. Eff. TEFC	230/460	213TC	V11742APE	17.8/8.9	20.2/10.1	75	1.15	90.2	F
10*	3	TEFC	208-230/460	215TC	V12742	25-24/12	30.5-27.6/13.8	105	1.15	85.5	F
		Prem. Eff. TEFC	230/460	215TC	V12742PE	23.8/11.9	27.6/13.8	112	1.15	89.5	F
15*	3	TEFC	208-230/460	254TC	V13742	35/17.5	43-39/19.5	165	1.15	86.5	F
		Prem. Eff. TEFC	208-230/460	254TC	V13742PE	34.4/17.2	43.8-39.6/19.8	112	1.15	91.7	F
20	3	TEFC	208-230/460	256TC	V14742	46/23	59.3-53.6/26.8	160	1.15	89.5	F
		Prem. Eff. TEFC	208-230/460	256TC	V14742PE	46/23	57.5-52/26	201	1.15	92.4	F
25	3	TEFC	230/460	284TC	V15742	59/29.5	74.8-67.6/33.8	182	1.15	88.5	F
		Prem. Eff. TEFC	230/460	284TC	V15742PE	56/28	69.9-63.2/31.6	236	1.15	93	F
30	3	TEFC	230/460	284TC	V16742	68/34	86.7-78.4/39.2	225	1.15	91	F
		Prem. Eff. TEFC	230/460	286TC	V16742PE	66/33	83.8-75.8/37.9	281	1.15	93	F
40	3	TEFC	230/460	284TC	V17742	90/45	103.2/51.6	322	1.15	90.2	F
		Prem. Eff. TEFC	230/460	324TSC	V17742PE	90/45	102.2/51.1	286	1.15	93.6	F
50	3	TEFC	230/460	326TSC	V18742S	112/56	141.8-128.2/64.1	430	1.15	92.4	F
		Prem. Eff. TEFC	230/460	326TSC	V18742SPE	108/54	124.8/62.4	422	1.15	94.1	F

NOTES:

① Locked rotor amps are for high voltage only.

* Currently available on Packaged Hydrovar.

• Motors are suitable for AQUAVAR® Variable Speed Drive.

Above data is for Baldor® TC and TSC frame motors. Specifications subject to change without notice.

Goulds Pumps

PHV - Packaged Hydrovar Series

PERFORMANCE WITH VARYING SPEED FOR CENTRIFUGAL PUMPS

Fitting the electric pump with a variable speed drive makes it possible to vary the pump rotation speed, normally according to the system pressure parameter. **Variations in electric pump speed** result in **modified performances** according to the equivalence relations, called affinity laws.

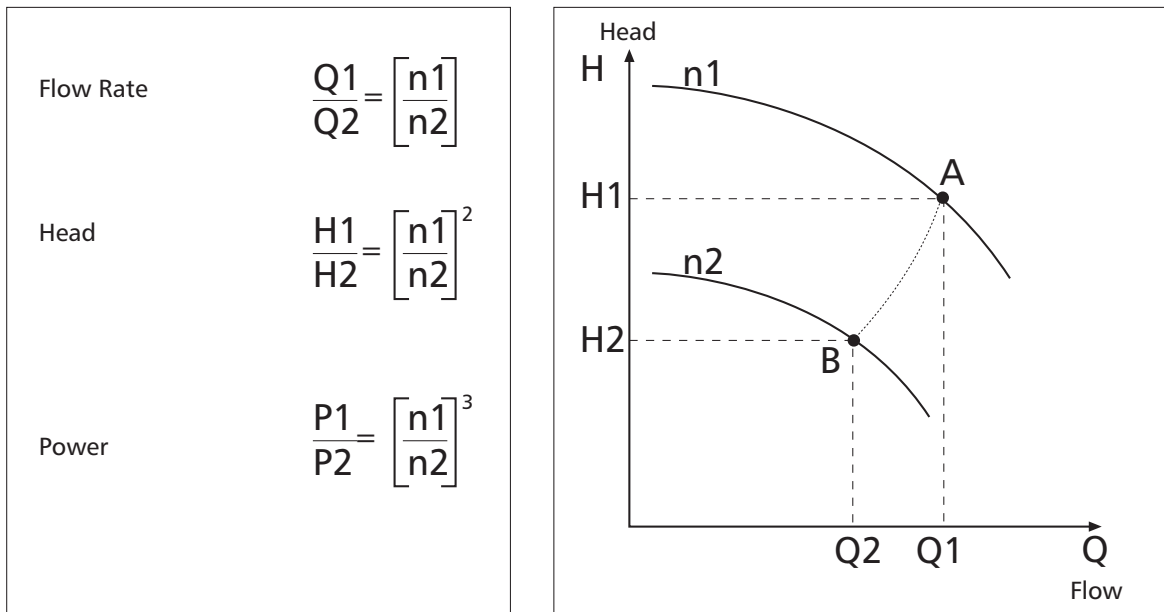

n1 = initial speed; n2= speed required.
Q1 = initial flow rate; Q2= flow rate required.
H1 = initial head; H2= head required.
P1 = initial power; P2= power required

Frequency ratios can be used instead of speed in practical applications, keeping 30 Hz as the bottom limit.

Example : 2-pole 50 Hz electric pump n1 =2900 (point A)

Flow rate (A) = 100 l/min; Head (A) = 50m

By reducing the frequency to 30 Hz the speed is reduced to approx. n2 = 1740 rpm (point B)

Flow rate (B) = 60 l/min; Head (B) = 18 m

The power of the new work point B is cut to about 22% of the initial power.

SIZING THE DIAPHRAGM TANK IN SYSTEMS WITH SPEED VARIATION

Variable speed booster sets need **smaller tanks** compared to traditional systems. Generally speaking, a tank with a capacity of just 20% of the nominal capacity of a single pump, expressed in gallons per minute, is needed. The **gradual starting** of the pumps controlled by the drive reduces the need to limit the number of hourly starts; the main purpose of the tank is to compensate for small system losses, stabilize the pressure and make up for pressure variations caused by sudden demand (fast acting valves).

Make the following calculation:

Set made up of three electric pumps, each with a maximum flow rate of 100 GPM, for a total capacity of 300 GPM. The **volume** required for the tank is 20 gallons. This is total capacity, not drawdown. Mount downstream of the check valves in discharge manifold.

VARIABLE SPEED PERFORMANCE CURVES

1SV VARIABLE SPEED CURVE

SSVB 304SS

Multi-Stage Pumps

MODEL: 1SVB 6 Stage

Hydraulic Data				
Maximum Flow	Flow at Duty Point	Maximum TDH	TDH at Duty Point	NPSH _R
22 US GPM		298 feet		

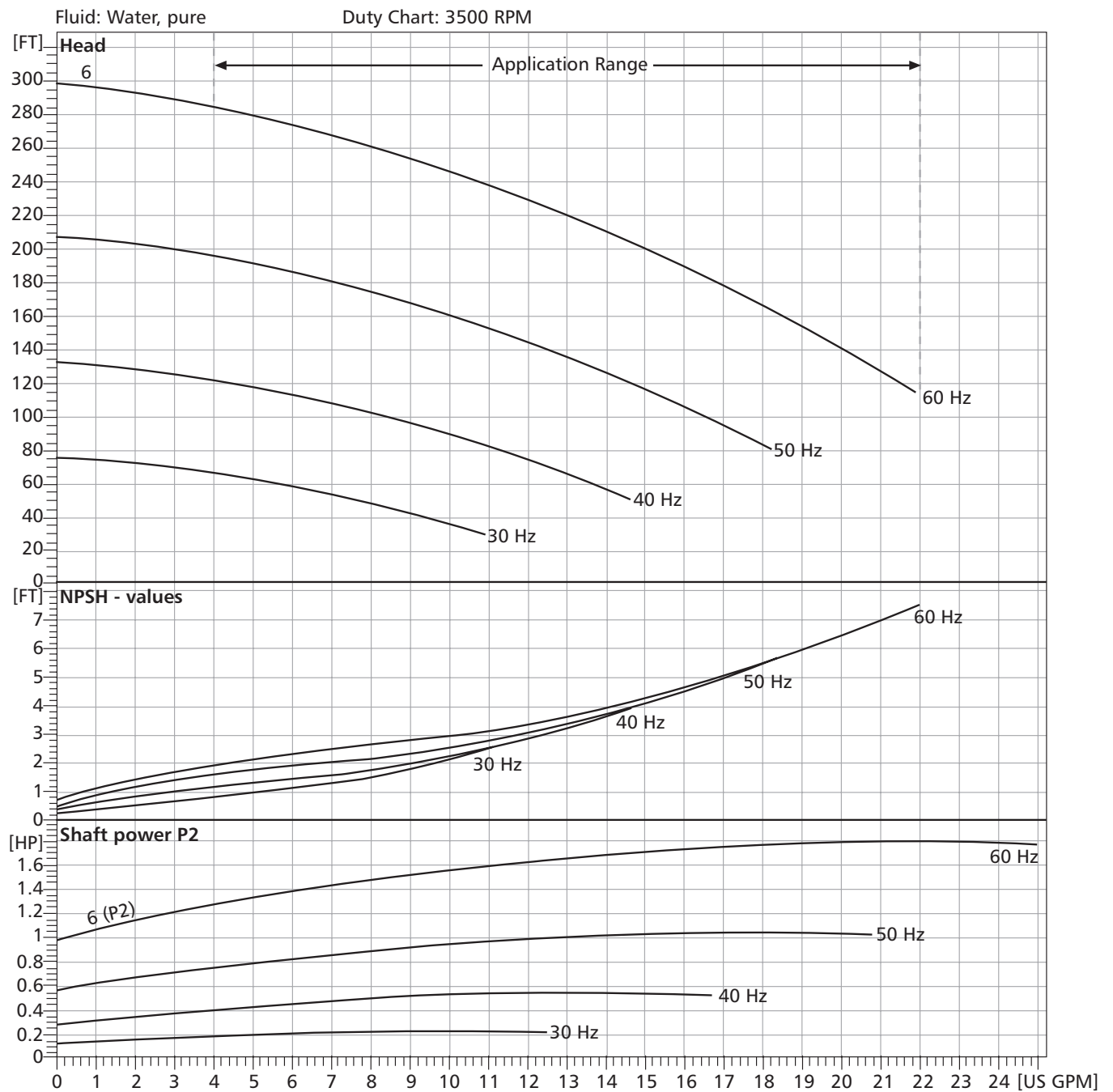

Goulds Pumps

PHV - Packaged Hydrovar Series

VARIABLE SPEED PERFORMANCE CURVES

1SV VARIABLE SPEED CURVE

SSVB 304SS

Multi-Stage Pumps

MODEL: 1SVB 9 Stage

Hydraulic Data				
Maximum Flow	Flow at Duty Point	Maximum TDH	TDH at Duty Point	NPSH _R
22 US GPM		442 feet		

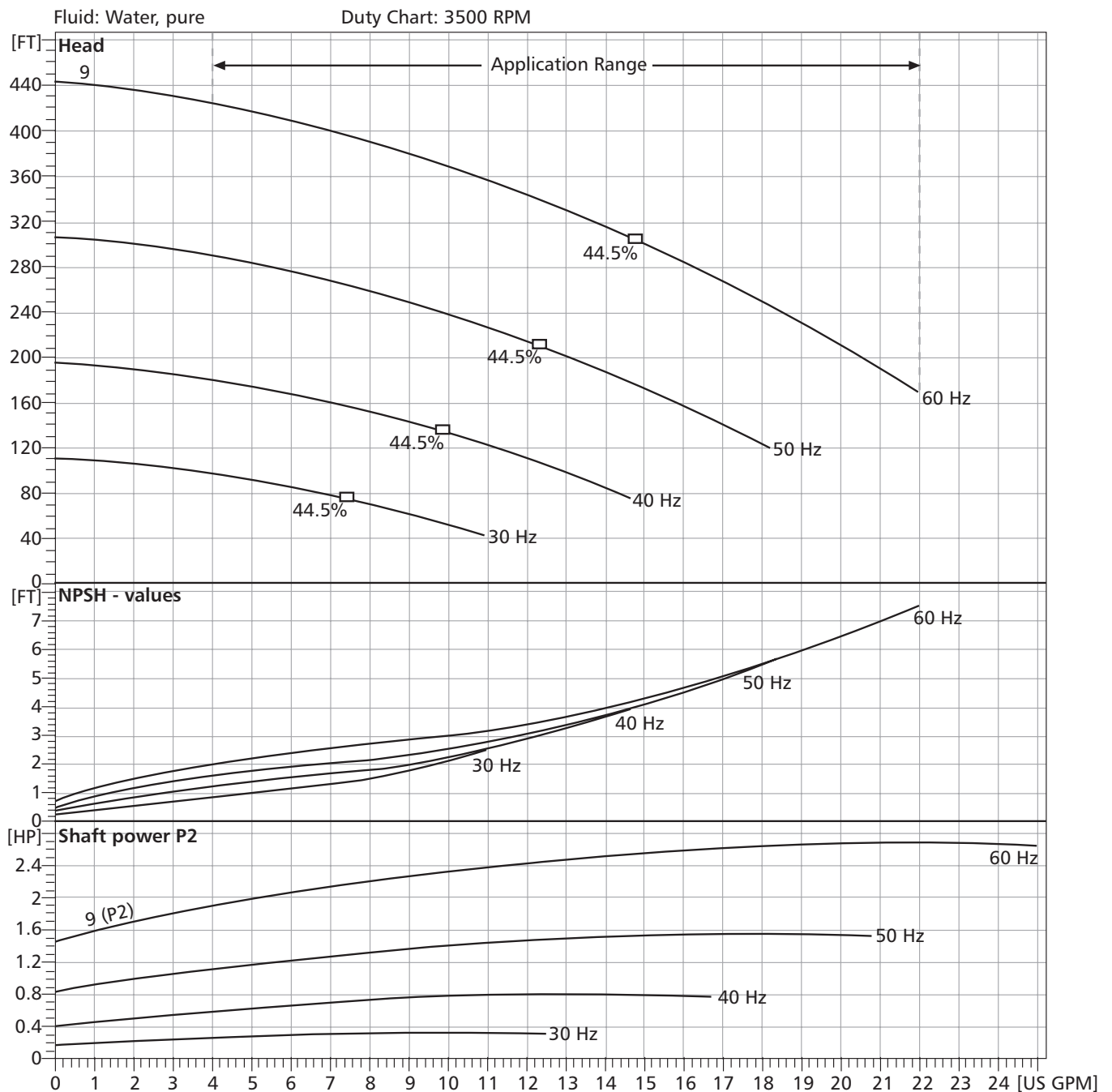

VARIABLE SPEED PERFORMANCE CURVES

1SV VARIABLE SPEED CURVE

SSVB 304SS

Multi-Stage Pumps

MODEL: 1SVB 15 Stage

Hydraulic Data				
Maximum Flow	Flow at Duty Point	Maximum TDH	TDH at Duty Point	NPSH _R
22 US GPM		733 feet		

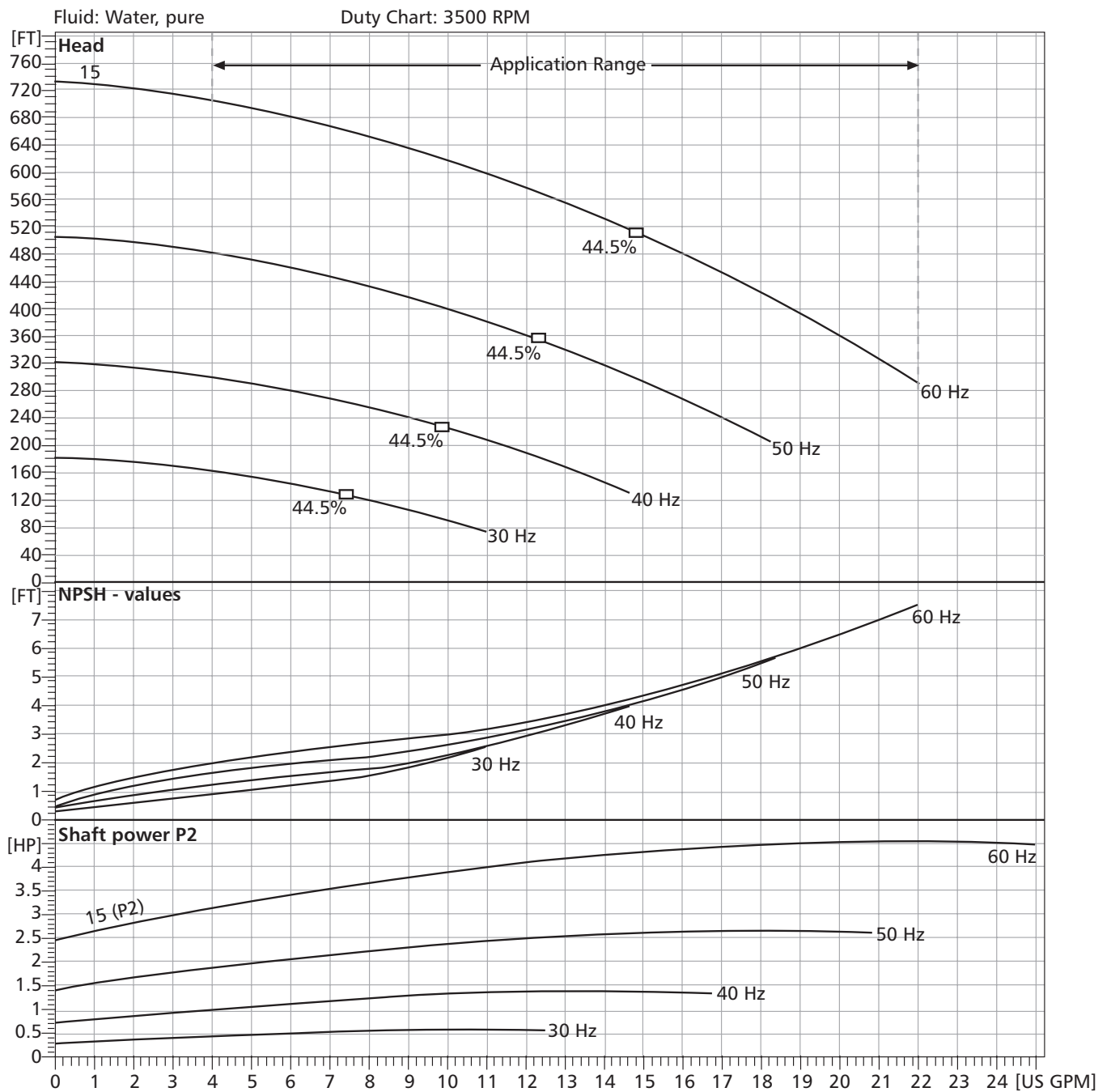

Goulds Pumps

PHV - Packaged Hydrovar Series

VARIABLE SPEED PERFORMANCE CURVES

2SV VARIABLE SPEED CURVE

SSVB 304SS

Multi-Stage Pumps

MODEL: 2SVB 5 Stage

Hydraulic Data				
Maximum Flow	Flow at Duty Point	Maximum TDH	TDH at Duty Point	NPSH _R
40 US GPM		217 feet		

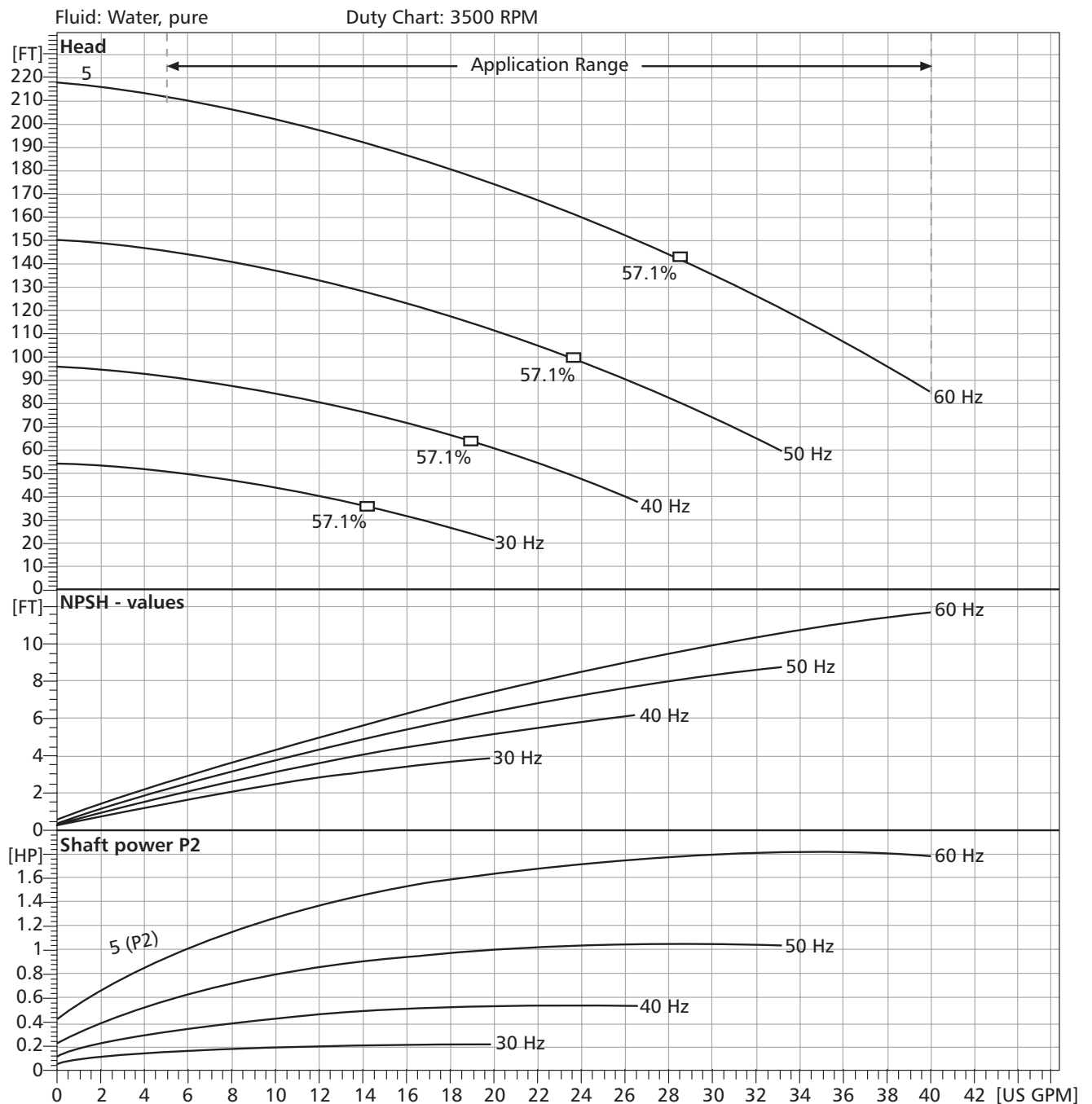

VARIABLE SPEED PERFORMANCE CURVES

2SV VARIABLE SPEED CURVE

SSVB 304SS

Multi-Stage Pumps

MODEL: 2SVB 8 Stage

Hydraulic Data				
Maximum Flow	Flow at Duty Point	Maximum TDH	TDH at Duty Point	NPSH _R
40 US GPM		353 feet		

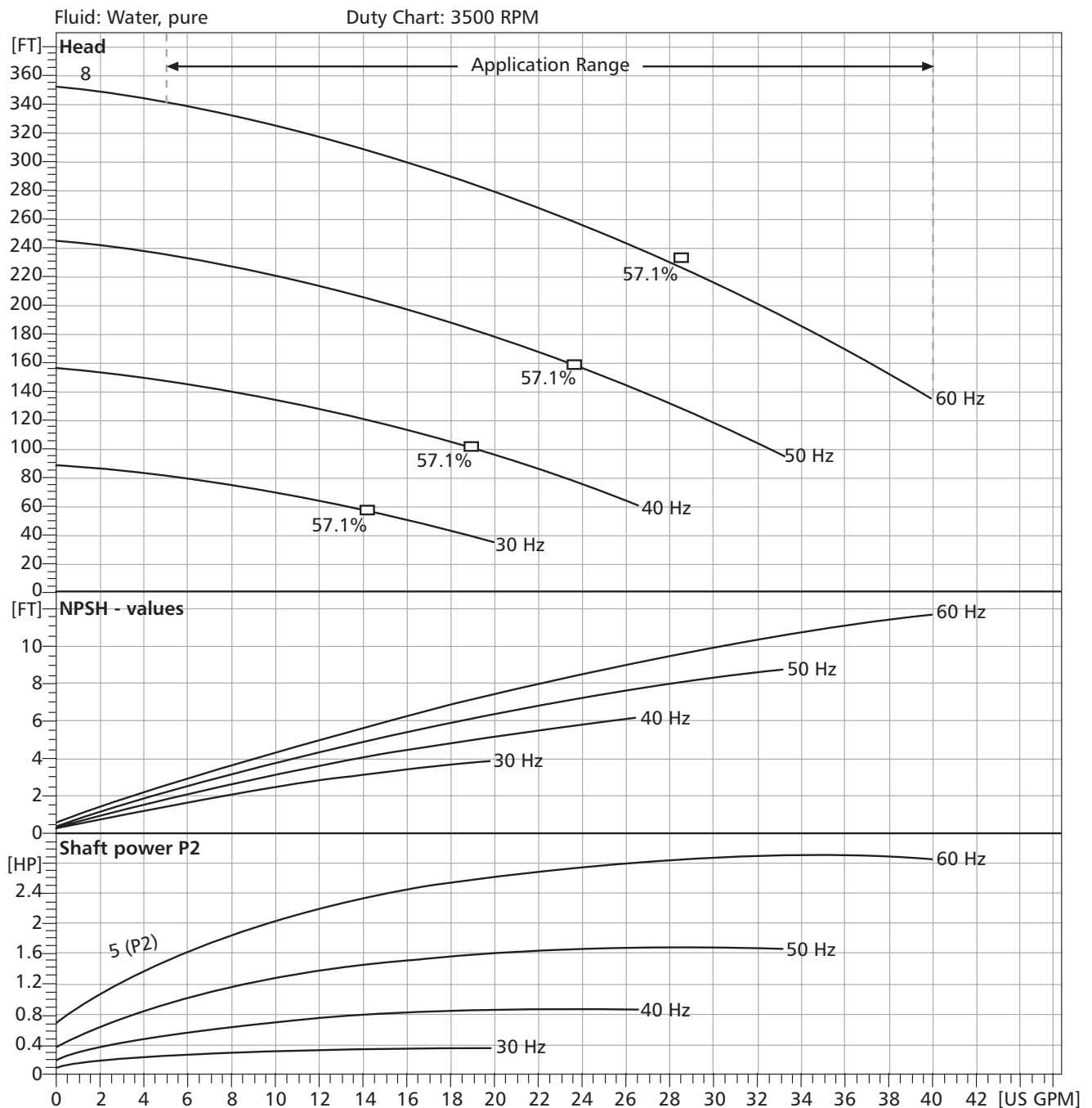

Goulds Pumps

PHV - Packaged Hydrovar Series

VARIABLE SPEED PERFORMANCE CURVES

2SV VARIABLE SPEED CURVE

SSVB 304SS

Multi-Stage Pumps

MODEL: 2SVB 13 Stage

Hydraulic Data				
Maximum Flow	Flow at Duty Point	Maximum TDH	TDH at Duty Point	NPSH _R
40 US GPM		586 feet		

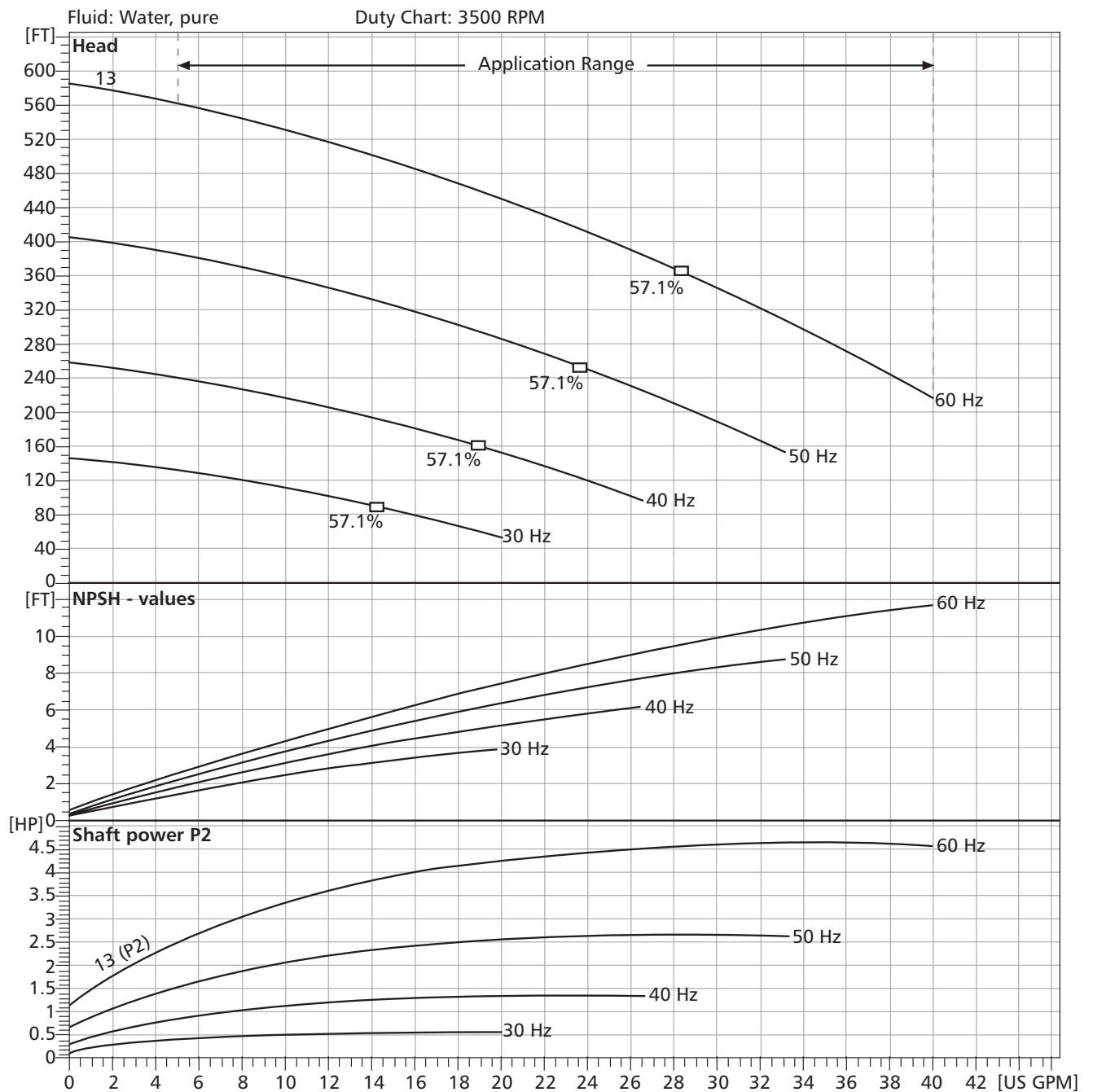

VARIABLE SPEED PERFORMANCE CURVES

3SV VARIABLE SPEED CURVE

SSVB 304SS

Multi-Stage Pumps

MODEL: 3SVB 7 Stage

Hydraulic Data				
Maximum Flow	Flow at Duty Point	Maximum TDH	TDH at Duty Point	NPSH _R
78 US GPM		441 feet		

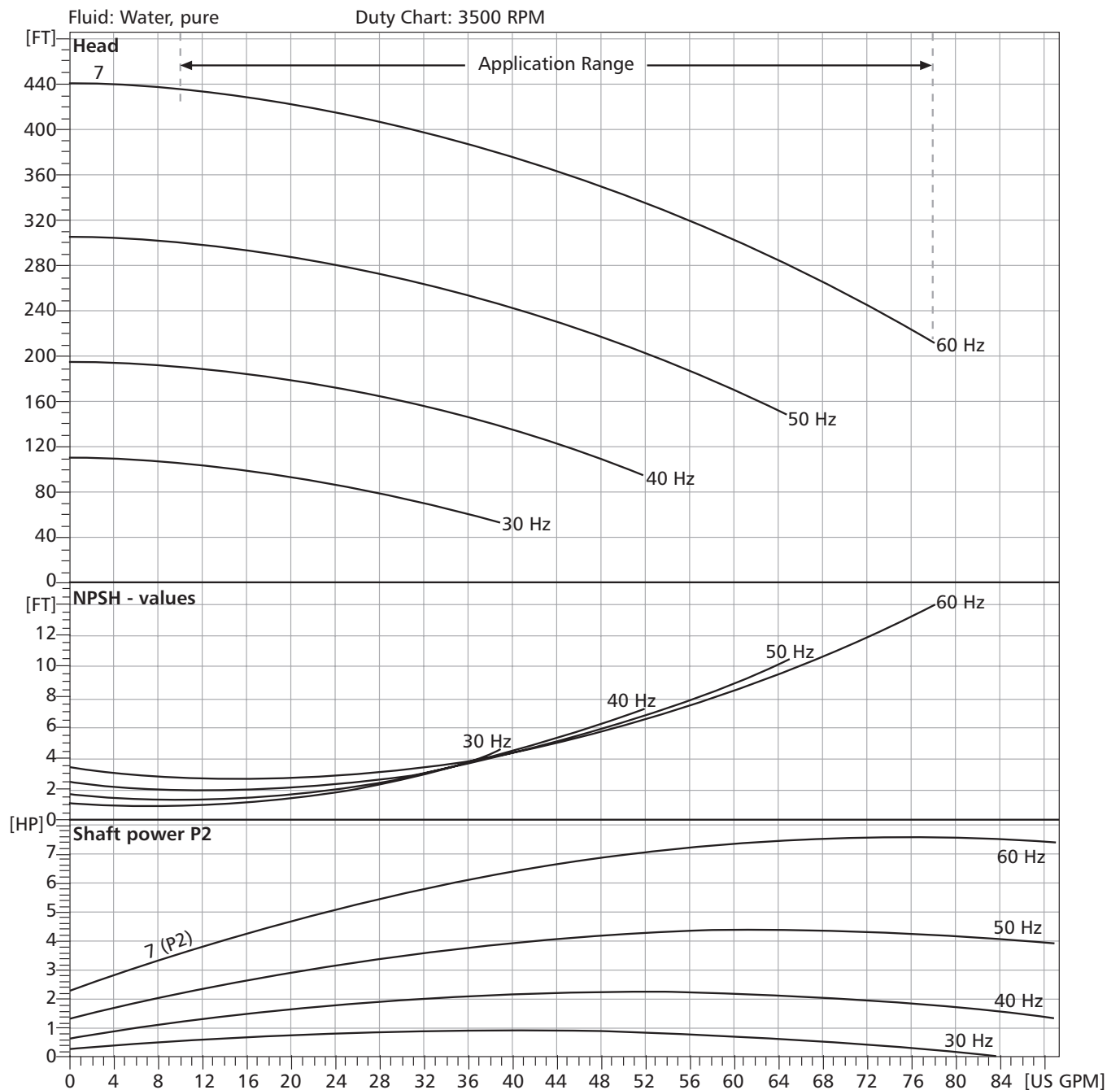

Goulds Pumps

PHV - Packaged Hydrovar Series

VARIABLE SPEED PERFORMANCE CURVES

3SV VARIABLE SPEED CURVE

SSVB 304SS

Multi-Stage Pumps

MODEL: 3SVB 9 Stage

Hydraulic Data				
Maximum Flow	Flow at Duty Point	Maximum TDH	TDH at Duty Point	NPSH _R
78 US GPM		565 feet		

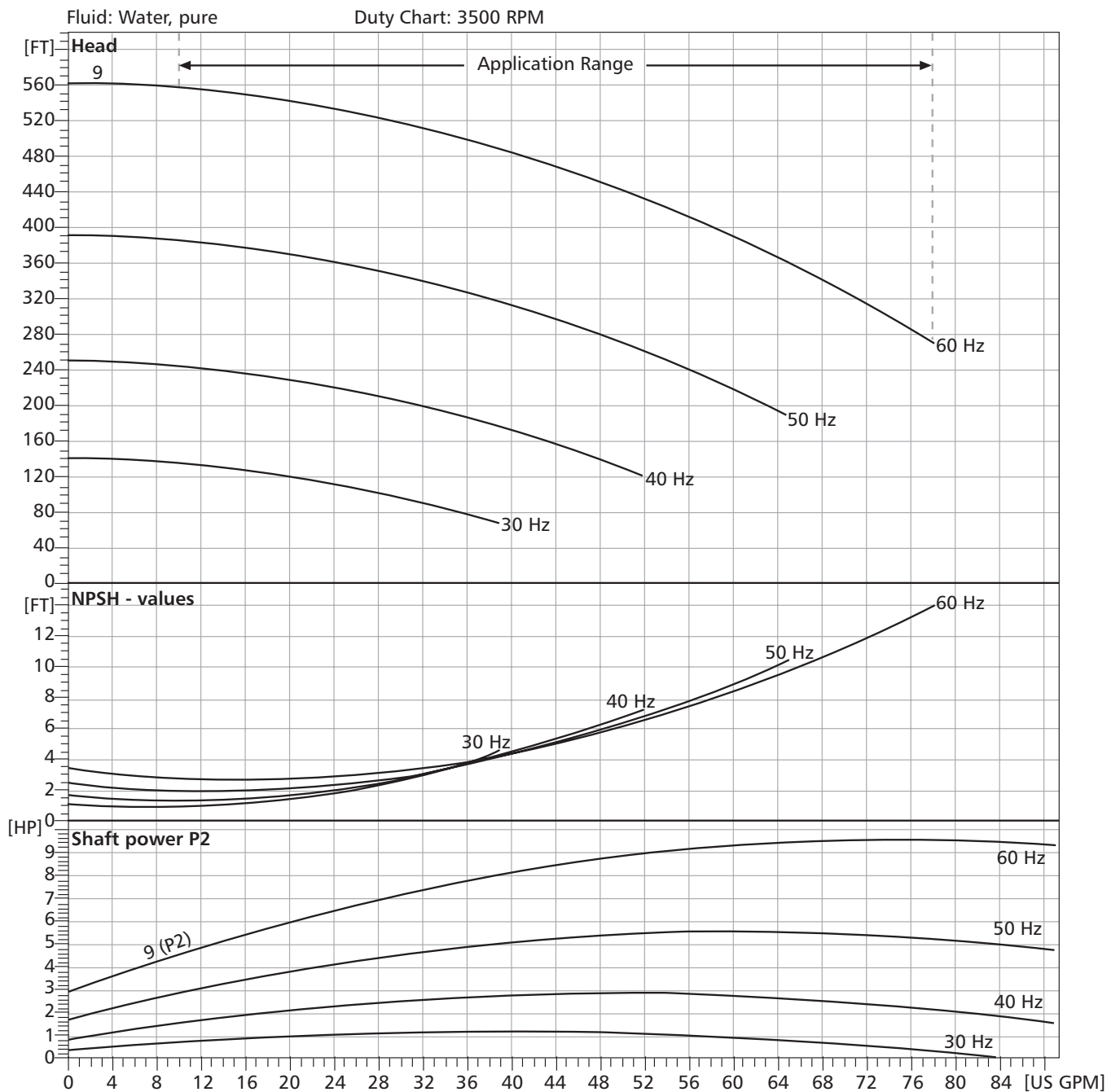

VARIABLE SPEED PERFORMANCE CURVES

3SV VARIABLE SPEED CURVE

SSVB 304SS

Multi-Stage Pumps

MODEL: 3SVB 13 Stage

Hydraulic Data				
Maximum Flow	Flow at Duty Point	Maximum TDH	TDH at Duty Point	NPSH _R
78 US GPM		817 feet		

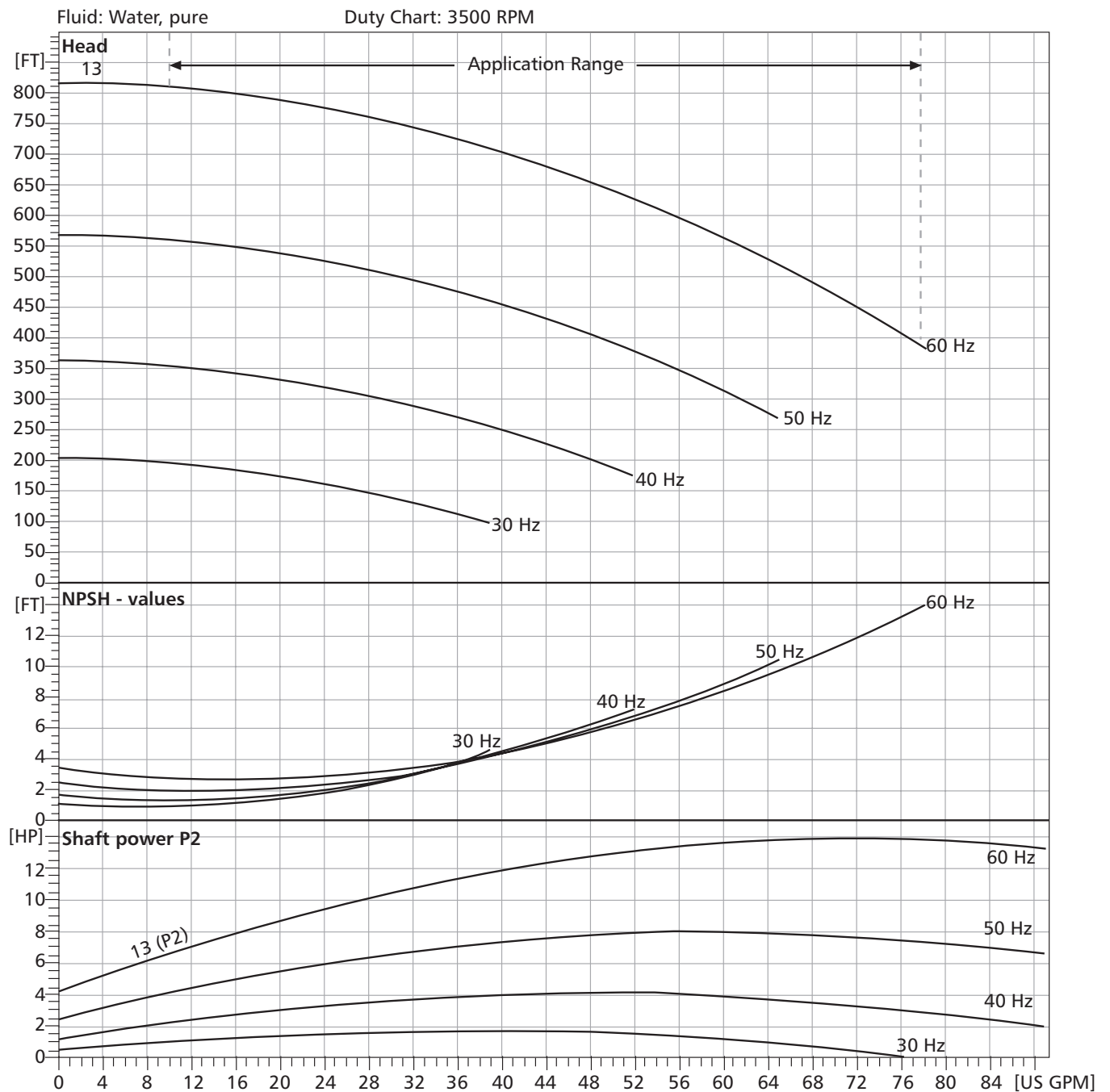

Goulds Pumps

PHV - Packaged Hydrovar Series

VARIABLE SPEED PERFORMANCE CURVES

4SV VARIABLE SPEED CURVE

SSVB 304SS

Multi-Stage Pumps

MODEL: 4SVB 2 Stage

Hydraulic Data				
Maximum Flow	Flow at Duty Point	Maximum TDH	TDH at Duty Point	NPSH _R
112 US GPM		148 feet		

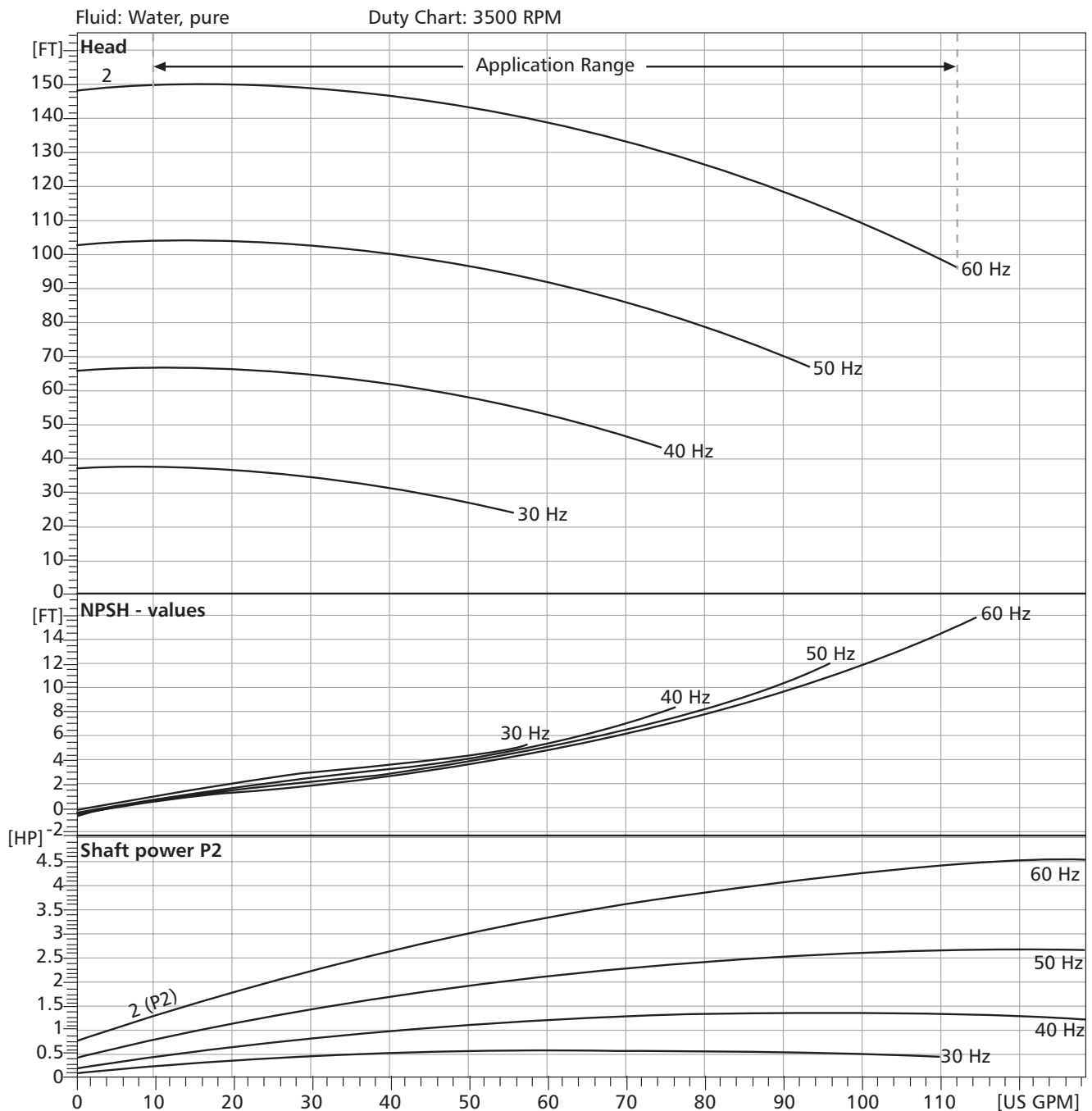

VARIABLE SPEED PERFORMANCE CURVES

4SV VARIABLE SPEED CURVE

SSVB 304SS

Multi-Stage Pumps

MODEL: 4SVB 4 Stage

Hydraulic Data				
Maximum Flow	Flow at Duty Point	Maximum TDH	TDH at Duty Point	NPSH _R
112 US GPM		299 feet		

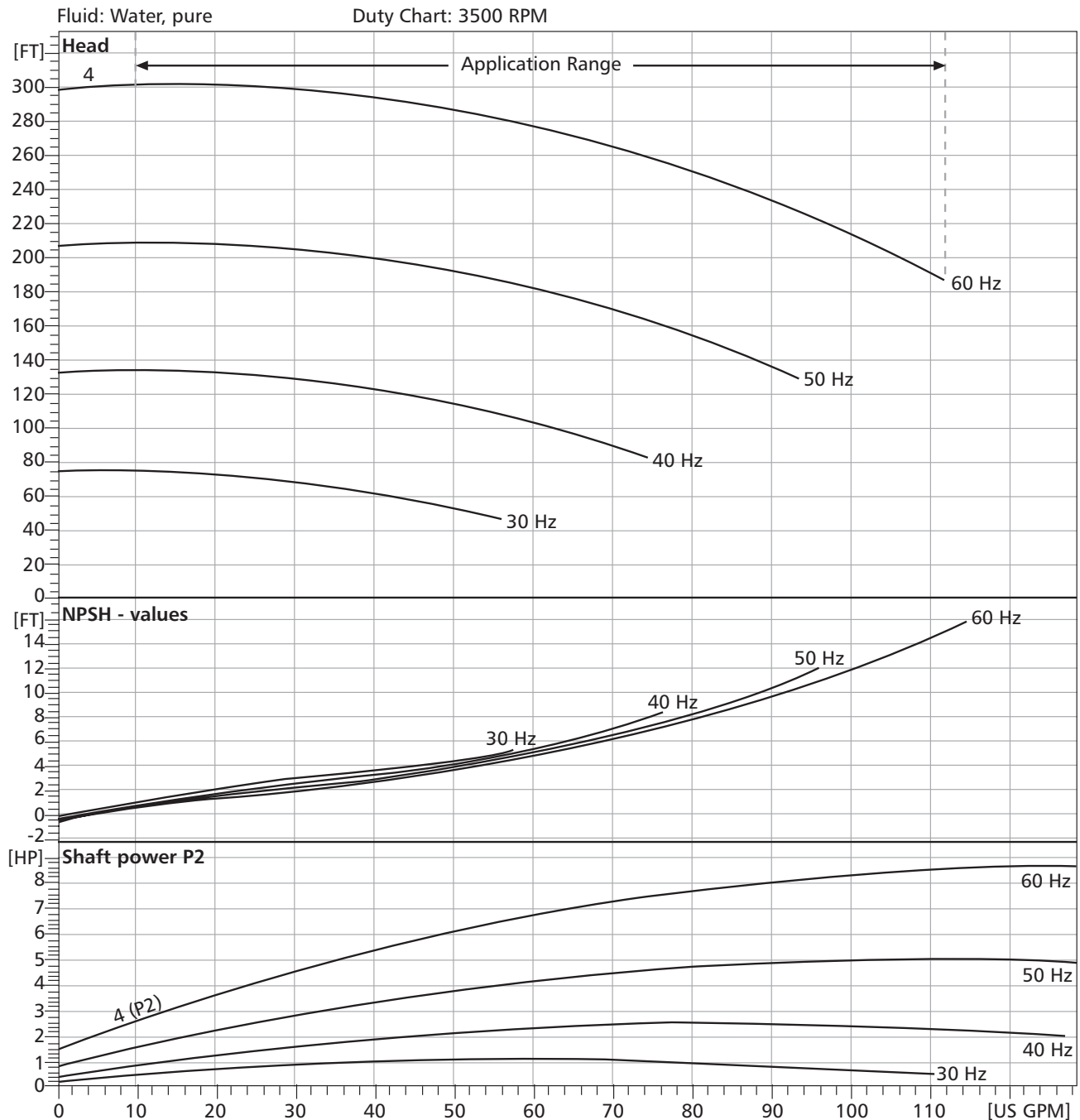

Goulds Pumps

PHV - Packaged Hydrovar Series

VARIABLE SPEED PERFORMANCE CURVES

4SV VARIABLE SPEED CURVE

SSVB 304SS

Multi-Stage Pumps

MODEL: 4SVB 7 Stage

Hydraulic Data				
Maximum Flow	Flow at Duty Point	Maximum TDH	TDH at Duty Point	NPSH _R
111 US GPM		526 feet		

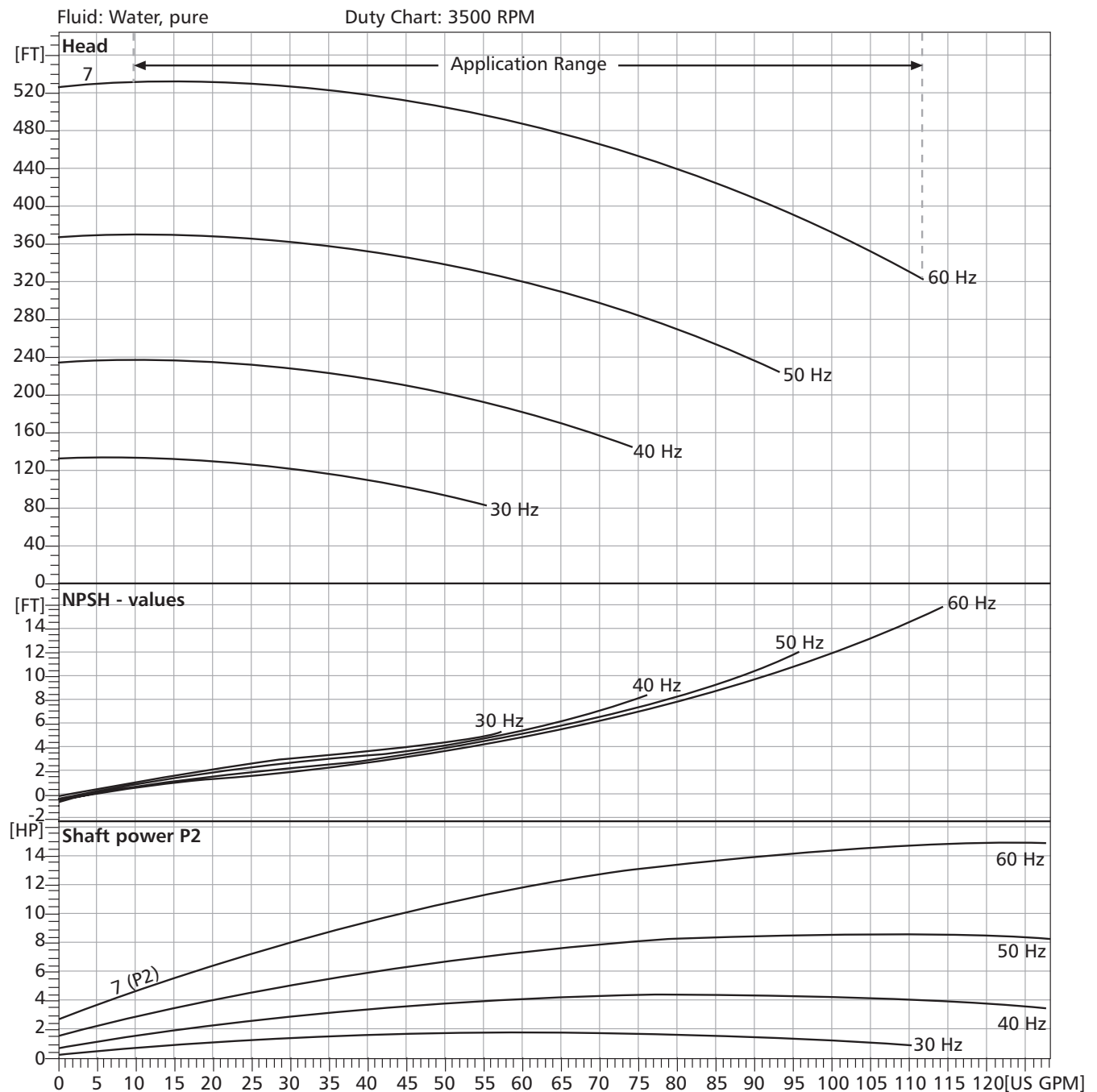

VARIABLE SPEED PERFORMANCE CURVES

33SV VARIABLE SPEED CURVE

SVB CI/316SS

Multi-Stage Pumps

MODEL: 33SVB 1/1 Stage

Hydraulic Data				
Maximum Flow	Flow at Duty Point	Maximum TDH	TDH at Duty Point	NPSH _R
225 US GPM		83 feet		

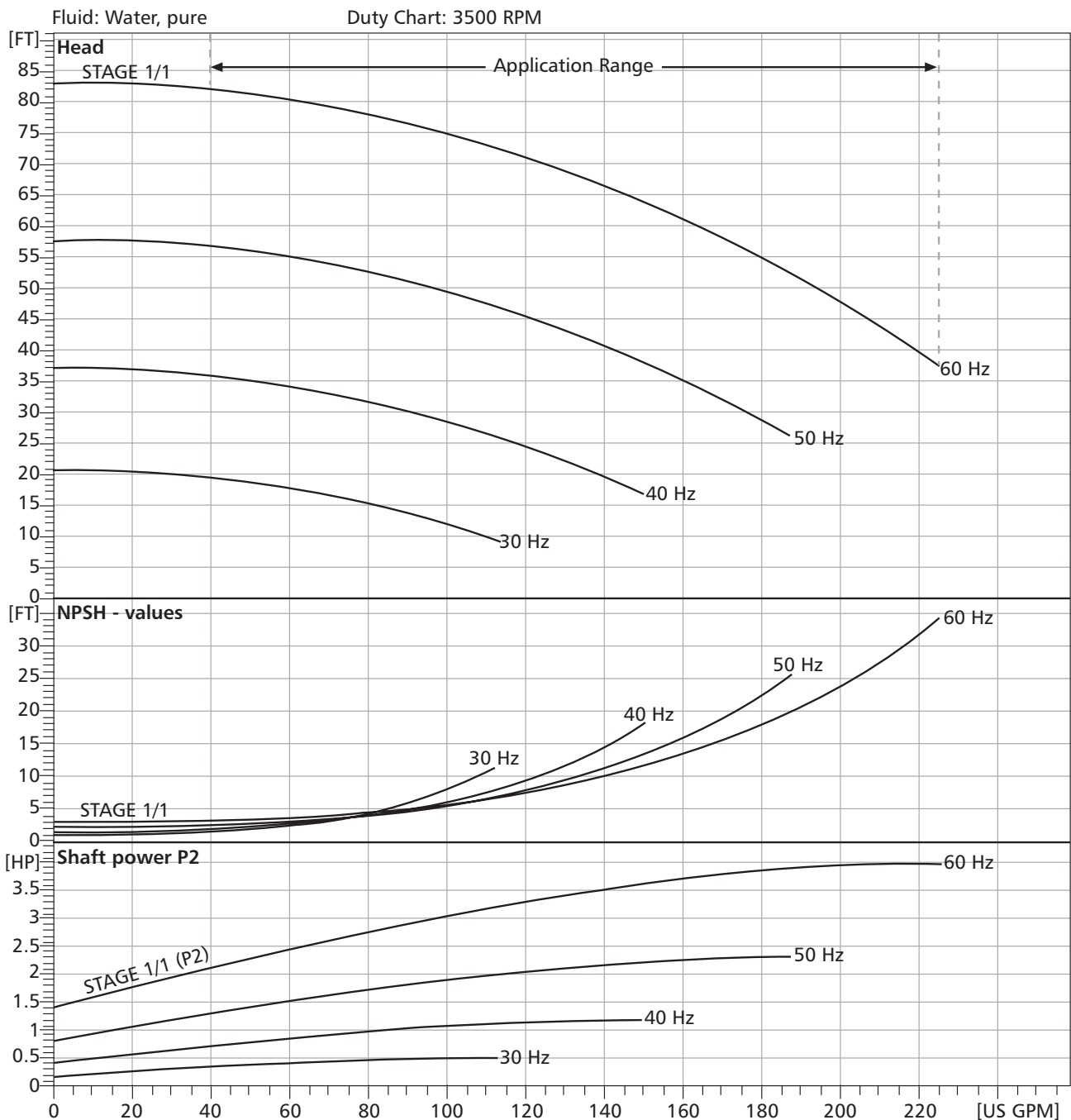

Goulds Pumps

PHV - Packaged Hydrovar Series

VARIABLE SPEED PERFORMANCE CURVES

33SV VARIABLE SPEED CURVE

SVB CI/316SS

Multi-Stage Pumps

MODEL: 33SVB 1 Stage

Hydraulic Data				
Maximum Flow	Flow at Duty Point	Maximum TDH	TDH at Duty Point	NPSH _R
224 US GPM		110 feet		

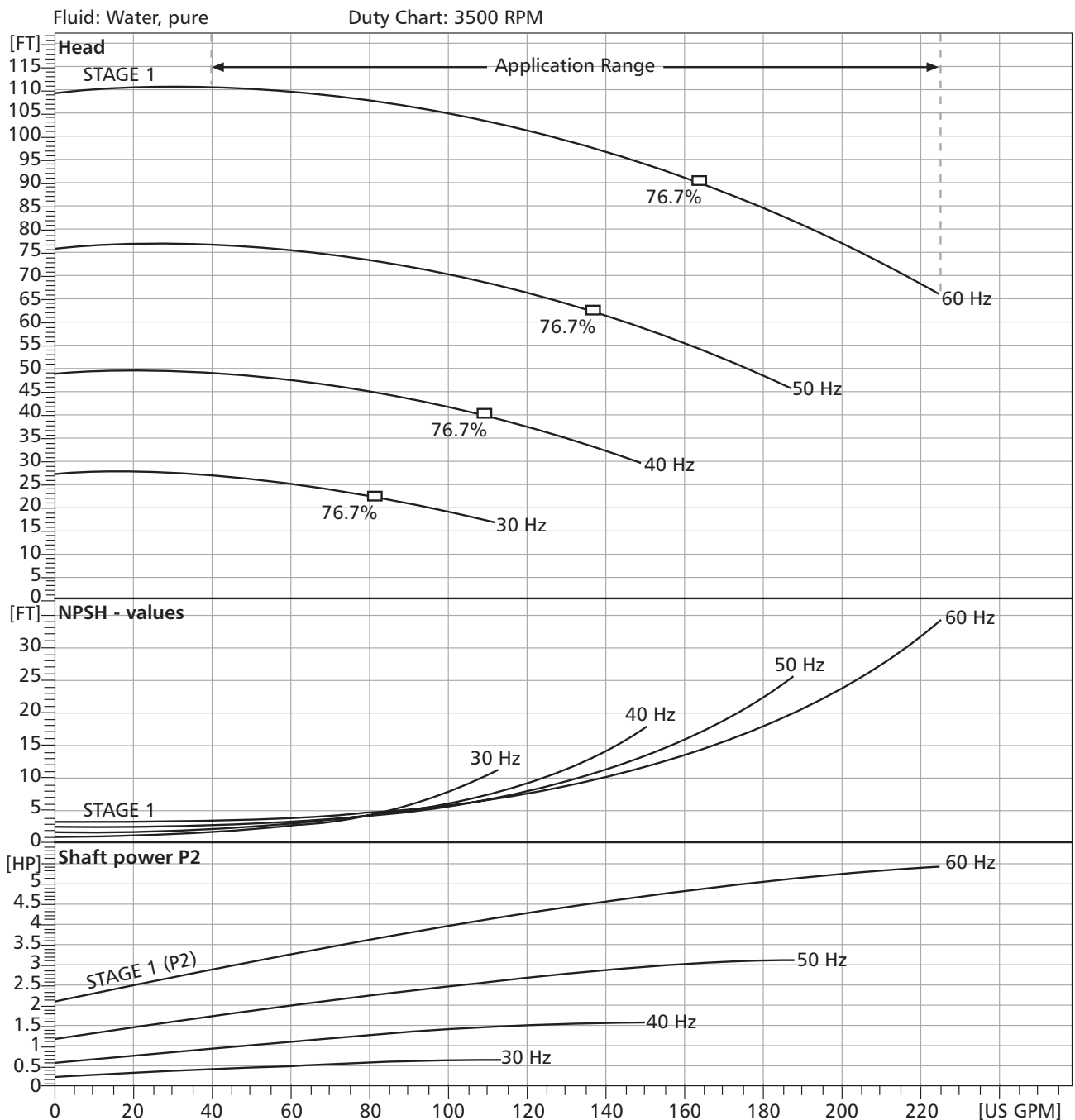

VARIABLE SPEED PERFORMANCE CURVES

33SV VARIABLE SPEED CURVE

SVB CI/316SS

Multi-Stage Pumps

MODEL: 33SVB 2/1 Stage

Hydraulic Data				
Maximum Flow	Flow at Duty Point	Maximum TDH	TDH at Duty Point	NPSH _R
225 US GPM		191 feet		

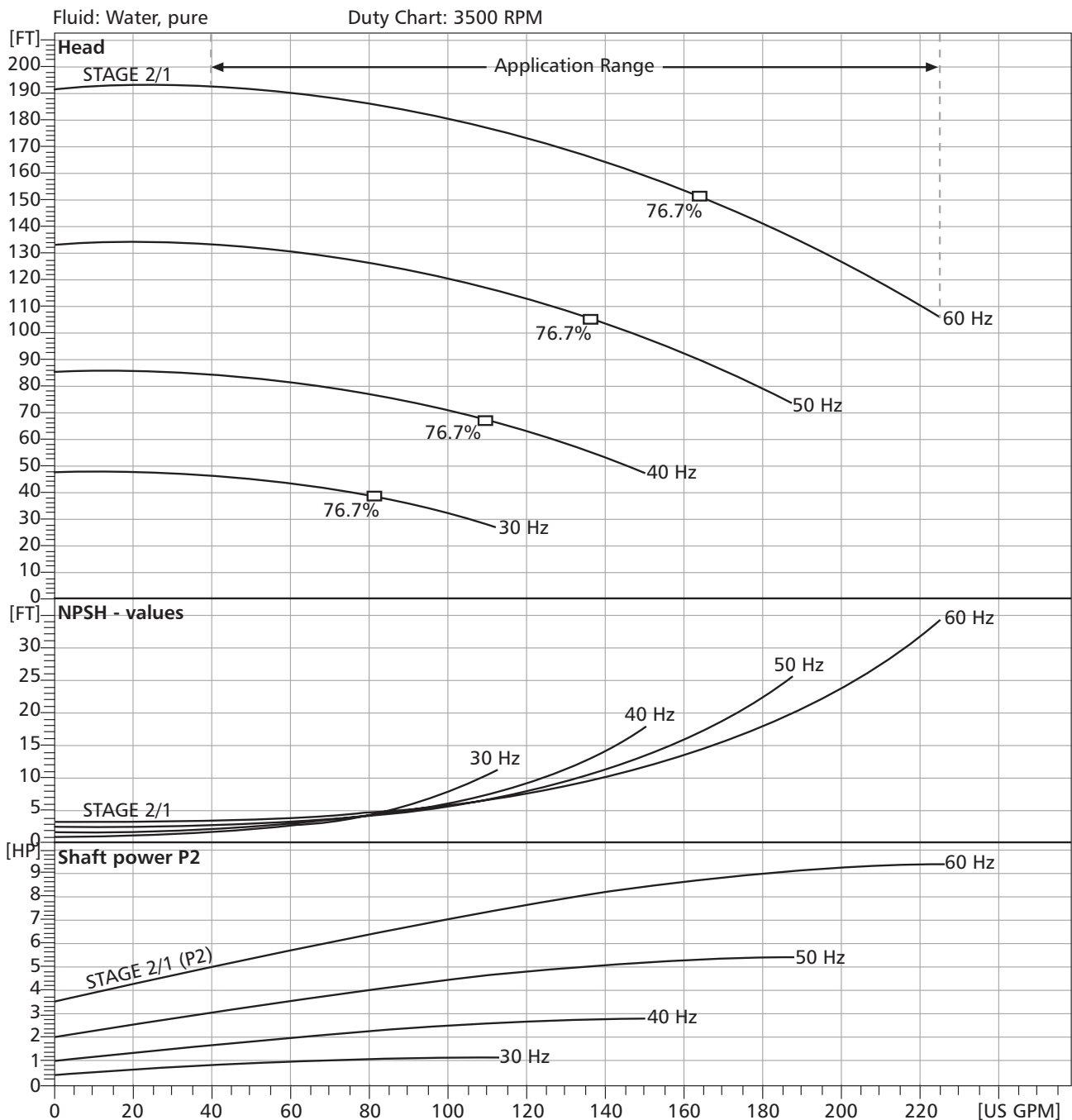

Goulds Pumps

PHV - Packaged Hydrovar Series

VARIABLE SPEED PERFORMANCE CURVES

33SV VARIABLE SPEED CURVE

SVB CI/316SS

Multi-Stage Pumps

MODEL: 33SVB 3/1 Stage

Hydraulic Data				
Maximum Flow	Flow at Duty Point	Maximum TDH	TDH at Duty Point	NPSH _R
225 US GPM		310 feet		

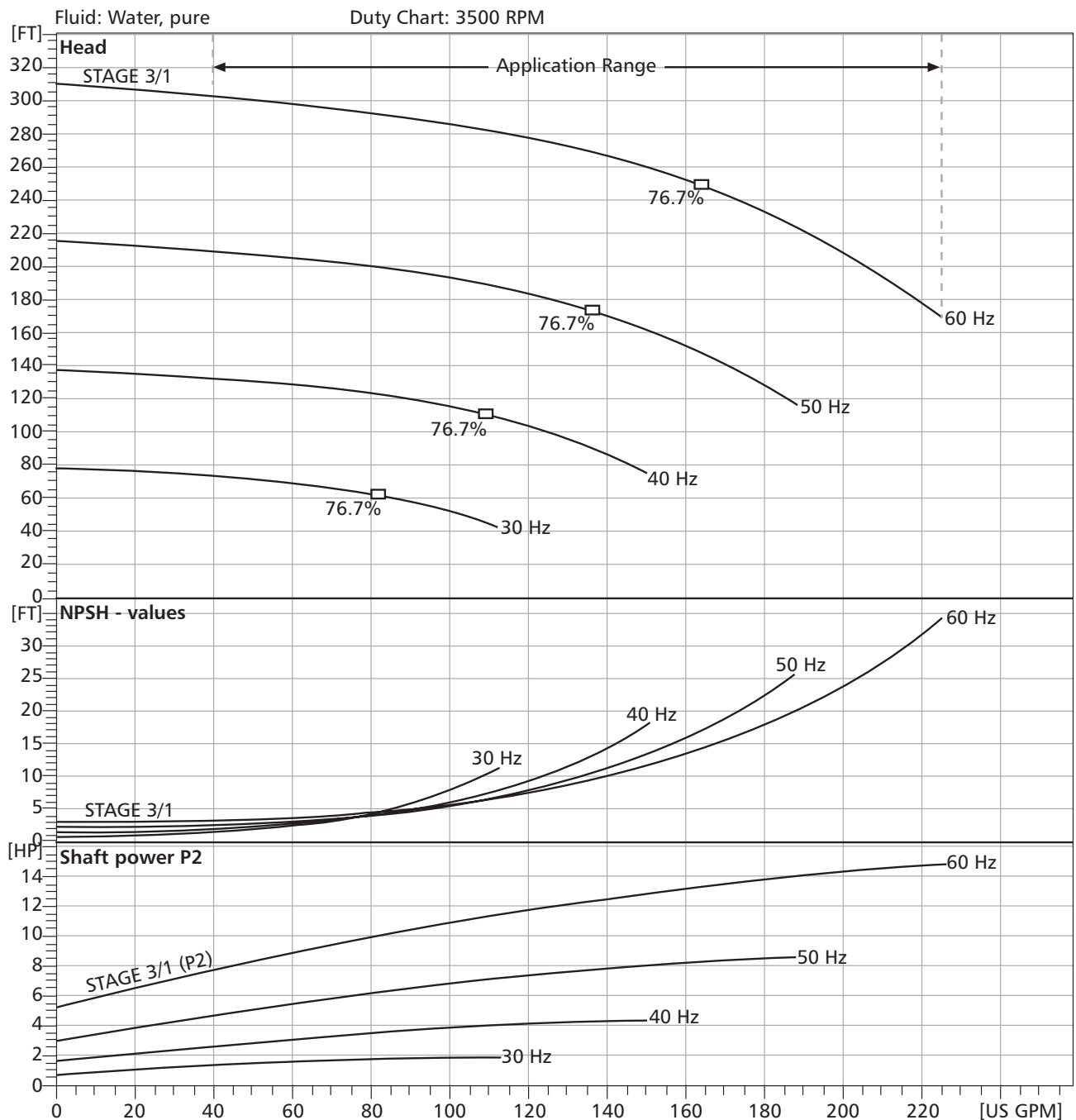

VARIABLE SPEED PERFORMANCE CURVES

46SV VARIABLE SPEED CURVE

SVB CI/316SS

Multi-Stage Pumps

MODEL: 46SVB 1/1 Stage

Hydraulic Data				
Maximum Flow	Flow at Duty Point	Maximum TDH	TDH at Duty Point	NPSH _R
319 US GPM		100 feet		

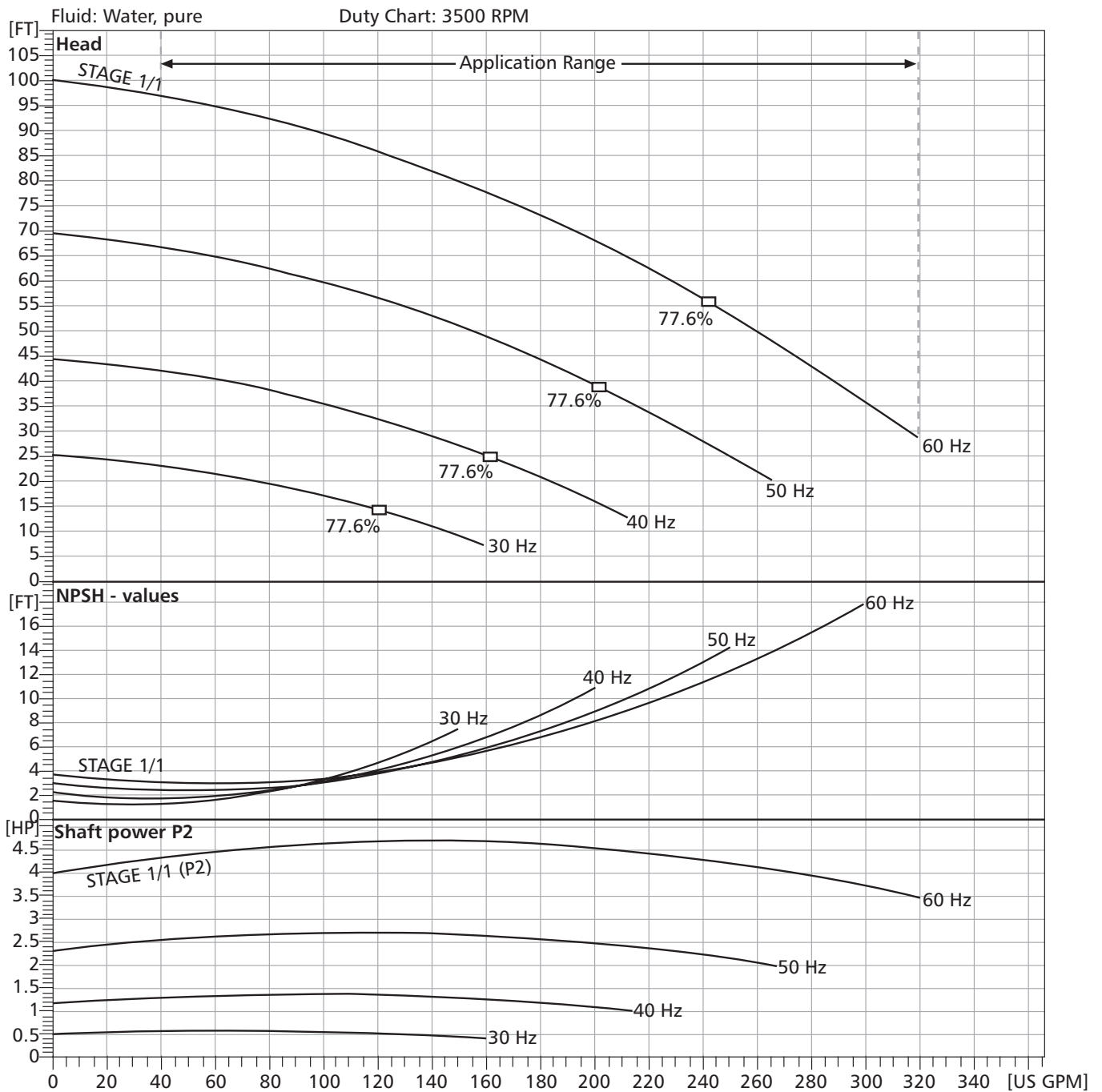

Goulds Pumps

PHV - Packaged Hydrovar Series

VARIABLE SPEED PERFORMANCE CURVES

46SV VARIABLE SPEED CURVE

SVB CI/316SS

Multi-Stage Pumps

MODEL: 46SVB 1 Stage

Hydraulic Data				
Maximum Flow	Flow at Duty Point	Maximum TDH	TDH at Duty Point	NPSH _R
319 US GPM		123 feet		

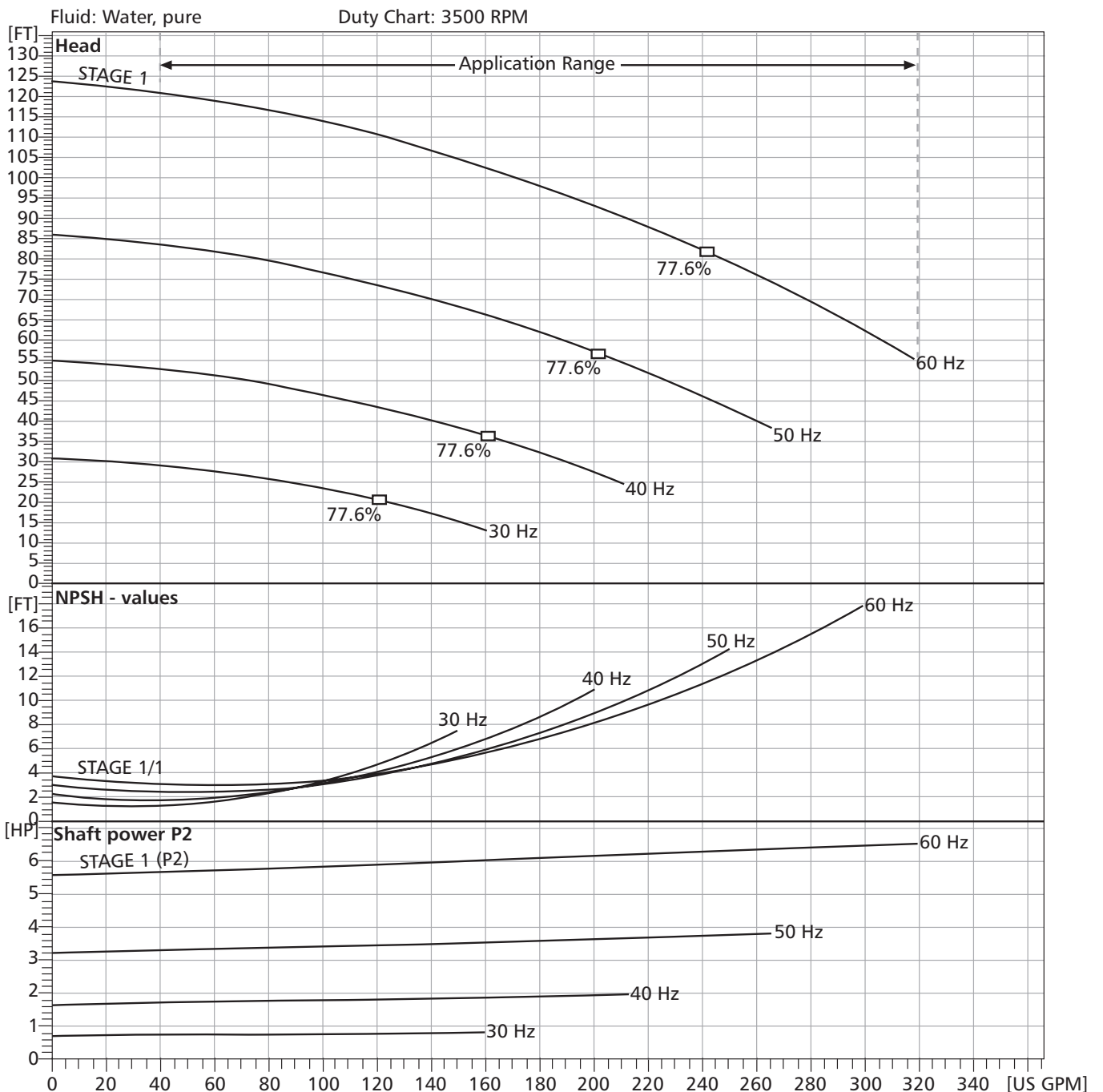

TECHNICAL DATA – PUMP HYDRAULICS / MOTOR SIZING

1SV 3500 RPM

Number of Stages	Maximum HP Draw	Motor HP for use With 1.15 SF Motor	Motor HP for use With Hydrovar (1.0 SF)	Shutoff TDH (Feet)	Shutoff TDH (Bar)	MAWP	Motor Rotation
22	6.7	7.5	7.5	1100	32.8	580 PSI (40 Bar)	CCW
20	6.1	7.5	7.5	1005	30.0		
18	5.4	5	7.5	905	27.0		
16	4.8	5	5	795	23.7	362 PSI (25 Bar)	CW
15	4.6	5	5	742	22.2		
13	4	5	5	642	19.2		
11	3.4	3	5	550	16.4		
9	2.7	3	3	445	13.3		
8	2.4	3	3	398	11.9		
7	2	2	2	350	10.4		
6	1.8	2	2	300	9.0		
5	1.5	1.5	1.5	250	7.5		
4	1.1	1	1.5	200	6.0		
3	0.9	3/4	1	142	4.2		
2	0.6	1/2	3/4	100	3.0		

2SV 3500 RPM

Number of Stages	Maximum HP Draw	Motor HP for use With 1.15 SF Motor	Motor HP for use With Hydrovar (1.0 SF)	Shutoff TDH (Feet)	Shutoff TDH (Bar)	MAWP	Motor Rotation
22	7.7	7.5	NA	950	28.4	580 PSI (40 Bar)	CCW
20	6.8	7.5	7.5	860	25.7		
18	6.2	7.5	7.5	760	22.7		
16	5.3	5	7.5	726	21.7	362 PSI (25 Bar)	CW
15	4.9	5	5	680	20.3		
13	4.6	5	5	595	17.8		
11	4	5	5	500	14.9		
9	3.3	3	5	407	12.2		
8	2.9	3	3	360	10.7		
7	2.4	3	3	315	9.4		
6	2.1	2	3	270	8.1		
5	1.8	2	2	222	6.6		
4	1.5	1.5	1.5	175	5.2		
3	1.1	1	1.5	137	4.1		
2	0.7	3/4	1	92	2.7		

3SV 3500 RPM

Number of Stages	Maximum HP Draw	Motor HP for use With 1.15 SF Motor	Motor HP for use With Hydrovar (1.0 SF)	Shutoff TDH (Feet)	Shutoff TDH (Bar)	MAWP	Motor Rotation
16	17.6	20	20	1010	30.2	580 PSI (40 Bar)	CCW
14	15	15	15	894	26.7		
13	14	15	15	830	24.8		
12	12.8	15	15	760	22.7	362 PSI (25 Bar)	CW
11	11.5	10	15	700	20.9		
10	10.7	10	15	640	19.1		
9	9.7	10	10	575	17.2		
8	8.5	7.5	10	505	15.1		
7	7.5	7.5	7.5	450	13.4		
6	6.5	7.5	7.5	380	11.3		
5	5.4	5	7.5	320	9.6		
4	4.3	5	5	250	7.5		
3	3.3	3	5	190	5.7		
2	2.2	2	3	128	3.8		

Goulds Pumps

PHV - Packaged Hydrovar Series

TECHNICAL DATA – PUMP HYDRAULICS / MOTOR SIZING

4SV 3500 RPM

Number of Stages	Maximum HP Draw	Motor HP for use With 1.15 SF Motor	Motor HP for use With Hydrovar (1.0 SF)	Shutoff TDH (Feet)	Shutoff TDH (Bar)	MAWP	Motor Rotation
12	26.4	25	NA	930	27.8	580 PSI (40 Bar)	CCW
10	21.6	20	25	780	23.3		
9	19.2	20	20	700	20.9	362 PSI (25 Bar)	CW
8	16.9	15	20	620	18.5		
7	14.9	15	15	540	16.1		
6	12.9	15	15	460	13.7		
5	10.7	10	15	390	11.6		
4	8.6	7.5	10	305	9.1		
3	6.3	7.5	7.5	228	6.8		
2	4.3	5	5	150	4.5		

33SV 3500 RPM

# of Impellers / # reduced Diameter	Maximum HP Draw	Motor HP for use with 1.15 SF Motor	Motor HP for use with Hydrovar (1.0 SF)	Shutoff TDH (Feet)	Shutoff TDH (Bar)	Casing / Sleeve Pressure rating (Standard Assy.)	Stages requiring Thrust Balancing Piston	Pump Flange Rating			
10	54.3	50	60	1125	34	40 Bar (580 PSI)	Thrust Piston Required	Class 250 / 300			
10/2	52.8			1096	33						
10/1	51.3			1066	32						
9	48.8		50	50	1012				30		
9/1	47.4				983				29		
9/2	45.9	954			28						
8	43.4	900			27						
8/1	41.9	871			26						
8/2	40.5	40	40	842	25				25 Bar (362 PSI) ①		Class 125 / 150
7	38			787	23						
7/1	36.5			758	23						
7/2	35			729	22						
6	32.6			30	30	576	20				
6/1	31.1	646	19								
6/2	29.6	617	18								
5	27.1	562	17								
5/1	25.7	25	25			533	16				
5/2	24.2			504	15						
4	21.7			450	13						
4/1	20.2			20	20	421	13				
4/2	18.8					392	12				
3	16.3	337	10								
3/1	14.7	15	15			310	9				
3/2	13.2					281	8				
2	10.9			225	7						
2/1	9.4			10	10	196	6				
2/2	7.9					167	5				
1	5.4	7.5	113			3					
1/1	4	5	84			3					

① Pump assembly may be modified for 40 bar (580 psi) application – contact factory.

TECHNICAL DATA – PUMP HYDRAULICS / MOTOR SIZING

46SV 3500 RPM

# of Impellers / # reduced Diameter	Maximum HP Draw	Motor HP for use with 1.15 SF Motor	Motor HP for use with Hydrovar (1.0 SF)	Shutoff TDH (Feet)	Shutoff TDH (Bar)	Casing / Sleeve Pressure rating (Standard Assy.)	Stages requiring Thrust Balancing Piston	Pump Flange Rating			
10/2	77.8	75	75	1210	36.1	40 Bar (580 PSI)	Thrust Piston Required	Class 250 / 300			
9	73.2			1137	33.9						
9/1	71.5			1111	33.2						
9/2	69.7			1085	32.4						
8	65	60	60	1010	30.2						
8/1	63.3			984	29.4						
8/2	61.6			959	28.6						
7	56.9			884	26.4						
7/1	55.2	50	50	858	25.6				25 Bar (362 PSI) ①		Class 125 / 150
7/2	53.4			832	24.8						
6	48.8			758	22.6						
6/1	47.1			732	21.9						
6/2	45.3	40	40	706	21.1						
5	40.7			632	18.9						
5/1	38.9			605	18.1						
5/2	37.2			580	17.3						
4	32.5	30	30	505	15.1						
4/1	30.8			479	14.3						
4/2	29			453	13.5						
3	24.4			379	11.3						
3/1	22.7	20	20	353	10.5						
3/2	20.9			327	9.8						
2	16.3	15	15	253	7.6						
2/1	14/5			226	6.7						
2/2	12.8			200	6.0						
1	8.5			10	127						
1/1	6.7	7.5	7.5	102	3.0						

66SV 3500 RPM

# of Impellers / # reduced Diameter	Maximum HP Draw	Motor HP for use with 1.15 SF Motor	Motor HP for use with Hydrovar (1.0 SF)	Shutoff TDH (Feet)	Shutoff TDH (Bar)	Casing / Sleeve Pressure rating (Standard Assy.)	Stages requiring Thrust Balancing Piston	Pump Flange Rating
6	73.2	75	75	850	25.4	40 Bar (580 PSI)	Thrust Piston Required	Class 250 / 300
6/1	70.2			822	24.5			
6/2	67.2			796	23.8			
5	61	60	60	707	21.1	25 Bar (362 PSI) ①		Class 125 / 150
5/1	58			681	20.3			
5/2	55	50	50	655	19.6			
4	48.8			566	16.9			
4/1	45.8			540	16.1			
4/2	42.8			513	15.3			
3	36.6	40	40	424	12.7			
3/1	33.6			398	11.9			
3/2	30.6			372	11.1			
2	24.4	25	25	283	8.4			
2/1	21.4			257	7.7			
2/2	18.4	20	20	230	6.9			
1	12.2			15	142	4.2		
1/1	9.2	10	10	115	3.4			

① Pump assembly may be modified for 40 bar (580 psi) application – contact factory.

Goulds Pumps

PHV - Packaged Hydrovar Series

TECHNICAL DATA

Maximum Inlet Pressure

The following table shows the maximum permissible inlet pressure. However, the actual inlet pressure + pressure against a closed valve must always be lower than the maximum permissible operating pressure.

Pump	Number of Stages	Maximum Inlet Pressure
1SV	2-16 Stages	145 psi (10 bar)
	17-22 Stages	215 psi (15 bar)
2SV	2-25 Stages	145 psi (10 bar)
	16-22 Stages	215 psi (15 bar)
3SV	2-13 Stages	145 psi (10 bar)
	14-16 Stages	215 psi (15 bar)
4SV	2-10 Stages	145 psi (10 bar)
	11-12 Stages	215 psi (15 bar)
33SV	1-10 Stages	215 psi (15 bar)
46SV	1-10 Stages	
66SV	1-6 Stages	
92SV	1-6 Stages	

PHV — PACKAGED HYDROVAR SERIES — 1SVB

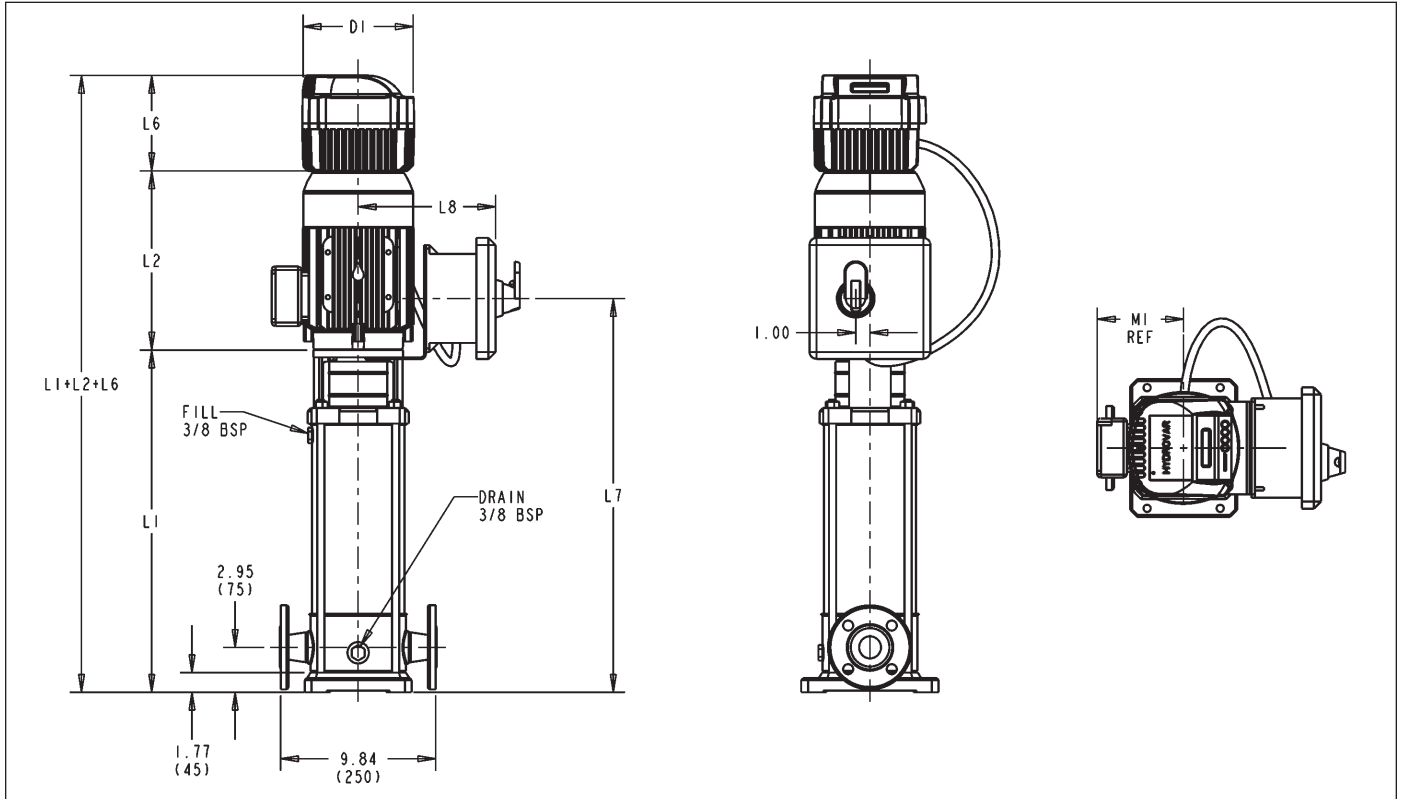

Stage	Frame (3-Phase) TEFC	HP	L1	L2					DI (max.)	Weights (lb.)				
				TEFC	L6	L7	L8	MI (ref.)		TEFC	Liquid End	TEFC	Hydrovar	Disconnect Box
6	56C	2	16.63	12.06		20.90	9.87	5.73	7.19	27	51			93
9		3	19.56	13.44	6.70	23.83				30	56	10	5	101
15	182-4TC	5	25.44	15.43		29.71	11.15	6.87	8.50	37	85			137

Goulds Pumps

PHV - Packaged Hydrovar Series

PHV — PACKAGED HYDROVAR SERIES — 2SVB

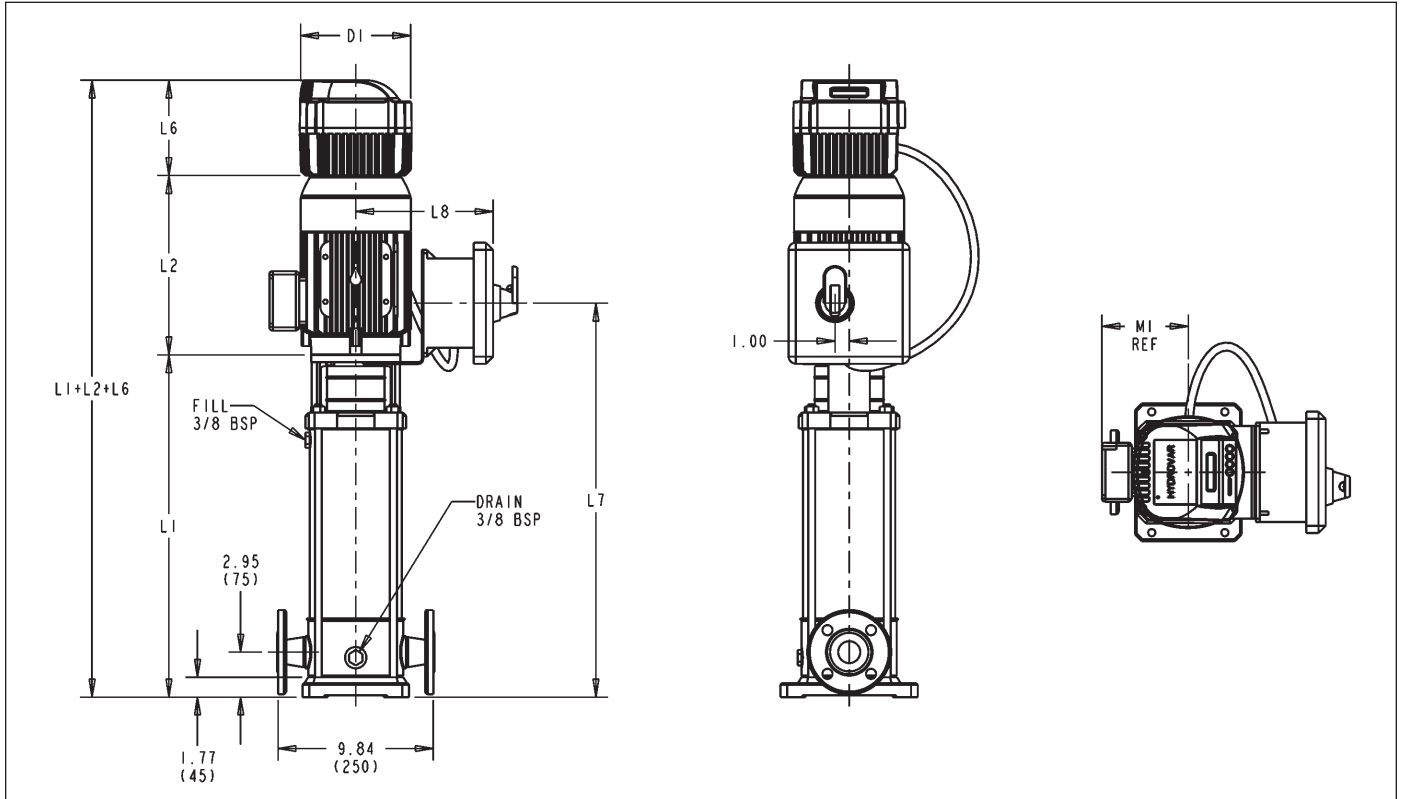

Stage	Frame (3-Phase) TEFC	HP	L1	L2	DI					Weights (lb.)				
				TEFC	L6	L7	L8	MI (ref.)	TEFC	Liquid End	TEFC	Hydrovar	Disconnect Box	Total Weight
5	56C	2	15.63	12.06	6.70	19.90	9.87	5.75	7.19	25	51	10	5	91
8		3	18.56	13.88		22.83		5.50		30	56			100
13	182-4TC	5	23.50	15.44		27.77	11.15	6.88		8.50	35			85
16			26.44		30.71	40					140			

PHV — PACKAGED HYDROVAR SERIES — 3SVB

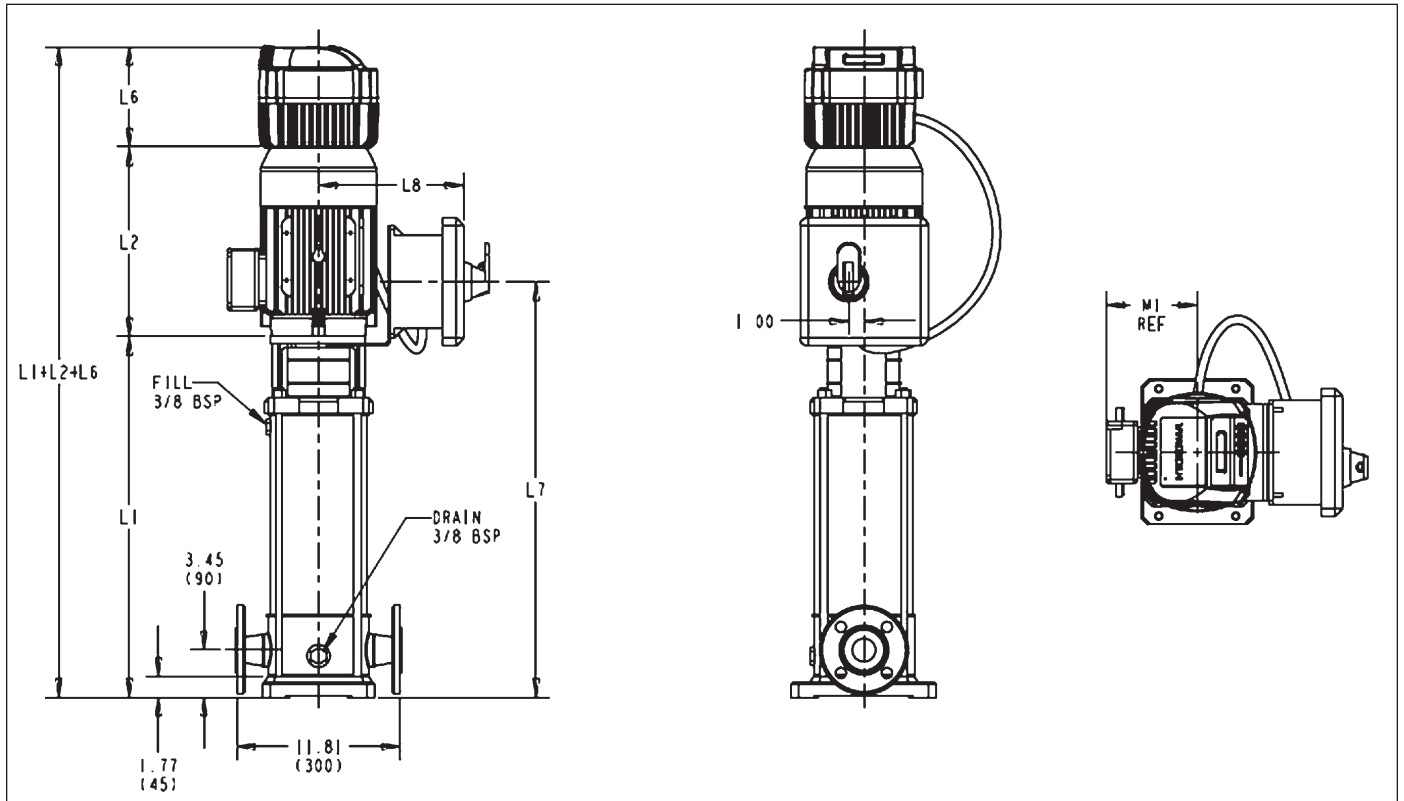

Stage	Frame (3-Phase) TEFC	HP	L1	L2					DI (max.)	Weights (lb.)				
				TEFC	L6	L7	L8	MI (ref.)	TEFC	Liquid End	TEFC	Hydrovar	Disconnect Box	Total Weight
2	56C	2	15.75	12.06		20.02	9.87	5.75	7.19	33	51			99
4		3	18.75			23.02				37	85			137
7	182-4TC	7½	23.25	15.44	6.70	27.52		6.88	8.50	45	124	10	5	184
9	215TC	10	28.88	15.50		33.15	11.15	8.06	10.25	47	151			221
13	254TC	15	33.38	16.56		37.65		9.25	10.83	66	250			339

Goulds Pumps

PHV - Packaged Hydrovar Series

PHV — PACKAGED HYDROVAR SERIES — 4SVB

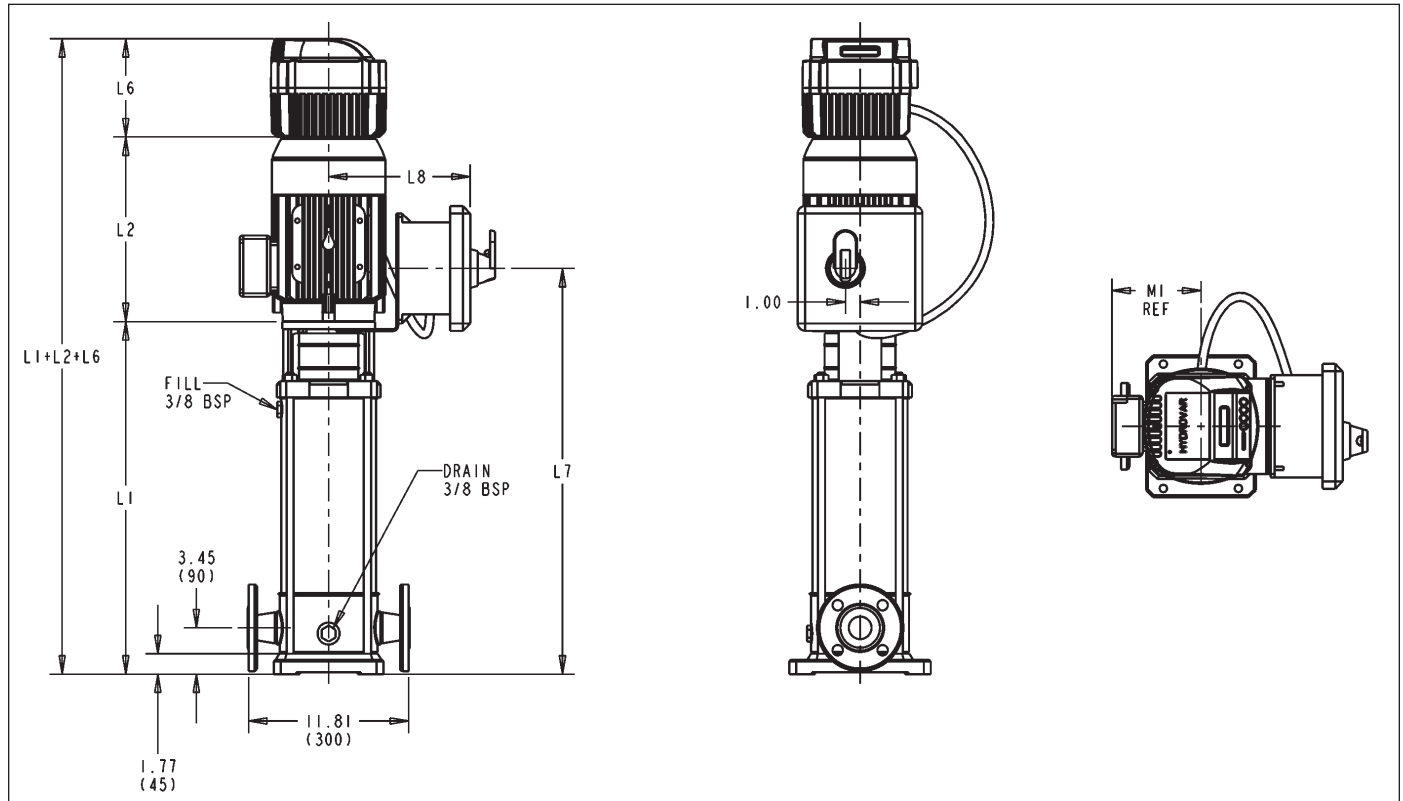

Stage	Frame (3-Phase) TEFC	HP	L1	L2					DI (max.)	Weights (lb.)				
				TEFC	L6	L7	L8	MI (ref.)	TEFC	Liquid End	TEFC	Hydrovar	Disconnect Box	Total Weight
2		5	15.75	15.44		20.02				33	85			133
4	182-4TC	7½	18.75	15.44	6.70	23.02	11.15	6.88	8.50	39	124	10	5	178
7	254TC	15	24.44	16.56		28.71		9.25	10.31	52	250			325

PHV — PACKAGED HYDROVAR SERIES — 33SVB

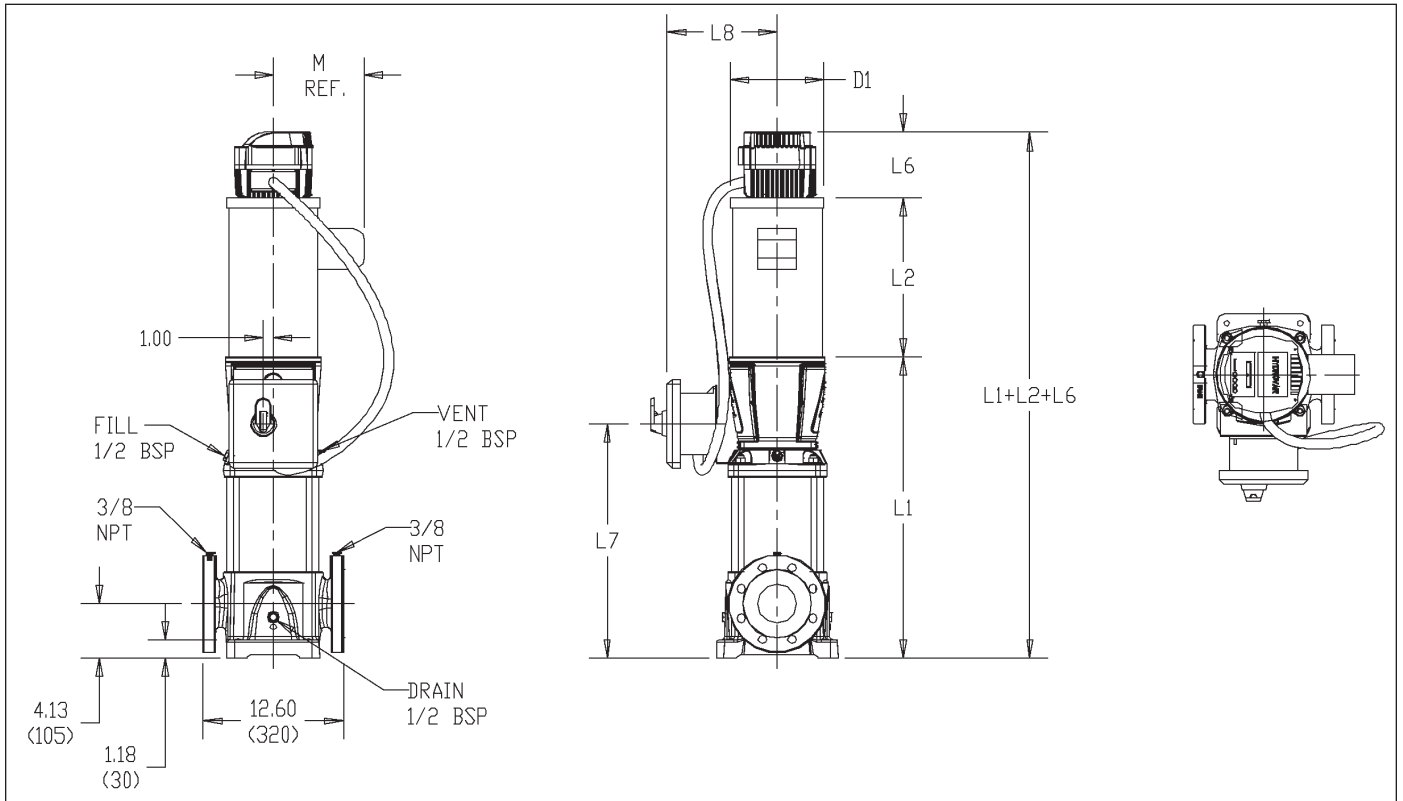

Stage	Frame (3-Phase) TEFC	HP	L1	L2		L6	L7	L8	DI (max.)		Weights (lb.)				
				TEFC	MI (ref.)				TEFC	Liquid End	TEFC	Hydrovar	Disconnect Box	Total Weight	
1/1	182-4TC	5	20.62	15.44			13.95		6.88	8.50	132	85	10		232
2/1	215TC	10	23.58	15.50	6.70		16.91	12.27	8.06	10.25	143	151	18	5	317
3/1	254TC	15	26.54	16.56			19.87		9.25	10.31	152	250			425

Goulds Pumps

PHV - Packaged Hydrovar Series

PHV — PACKAGED HYDROVAR SERIES — 46SVB

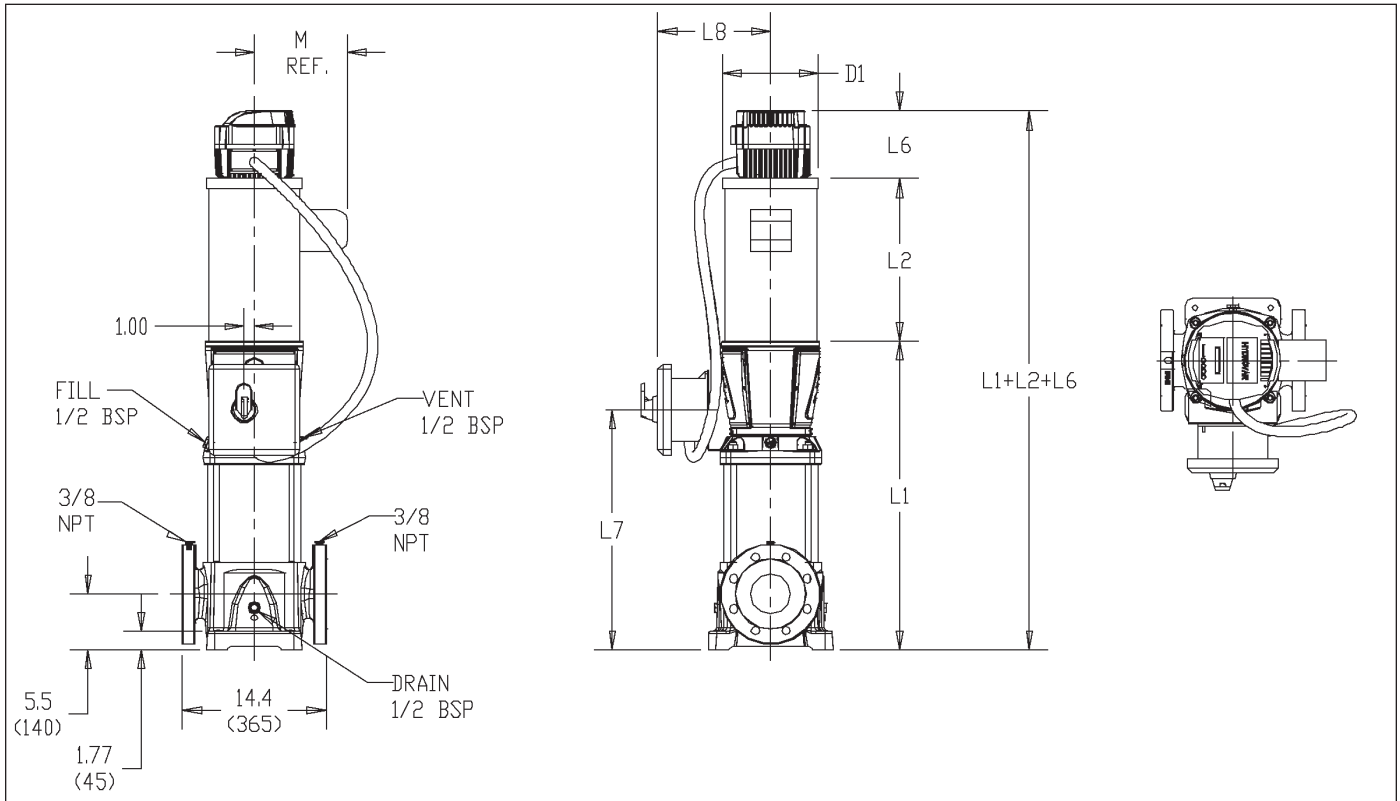

Stage	Frame (3-Phase) TEFC	HP	L1	L2		L6	L7	L8	DI (max.)		Weights (lb.)			
				TEFC					MI (ref.)	TEFC	Liquid End	TEFC	Hydrovar	Disconnect Box
1/1	182-4TC	7½		15.44					6.88	8.50	124			286
1	215TC	10	22.19	15.50	6.70	15.52	12.27	8.06	10.25	147	151	10	5	313
2/1	254TC	15	25.19	16.56		18.52		9.25	10.31	158	250	18		431

NPSH

The minimum operating values that can be reached at the pump suction end are limited by the onset of cavitation.

Cavitation is the formation of vapor-filled cavities within liquids where the pressure is locally reduced to a critical value, or where the local pressure is equal to, or just below the vapor pressure of the liquid.

The vapor-filled cavities flow with the current and when they reach a higher pressure the vapor contained in the cavities condenses. The cavities collide, generating pressure waves that are transmitted to the walls. These, being subjected to stress cycles, gradually become deformed and yield due to fatigue. This phenomenon, characterized by a metallic noise produced by the hammering on the pipe walls, is called incipient cavitation.

The damage caused by cavitation may be magnified by electrochemical corrosion and a local rise in temperature due to the plastic deformation of the walls. The materials that offer the highest resistance to heat and corrosion are alloy steels, especially austenitic steel. The conditions that trigger cavitation may be assessed by calculating the total net suction head, referred to in technical literature with the acronym NPSH (Net Positive Suction Head).

The NPSH represents the total energy (expressed in feet) of the liquid measured at suction under conditions of incipient cavitation, excluding the vapor pressure (expressed in feet) that the liquid has at the pump inlet.

To find the static height (h_z) at which to install the machine under safe conditions, the following formula must be verified:

$$h_p + h_z \geq (\text{NPSHr} + 2 \text{ feet}) + h_f + h_{pv}$$

where:

h_p is the absolute pressure applied to the free liquid surface in the suction tank, expressed in feet of liquid; h_p is the quotient between the barometric pressure and the specific weight of the liquid.

h_z is the suction lift between the pump axis and the free liquid surface in the suction tank, expressed in feet; h_z is negative when the liquid level is lower than the pump axis.

h_f is the flow resistance in the suction line and its accessories, such as: fittings, foot valve, gate valve, elbows, etc.

h_{pv} is the vapor pressure of the liquid at the operating temperature, expressed in feet of the liquid. h_{pv} is the quotient between the P_v vapor pressure and the liquid's specific weight.

0.5 is the safety factor.

The maximum possible suction head for installation depends on the value of the atmospheric pressure (i.e. the elevation above sea level at which the pump is installed) and the temperature of the liquid.

To help the user, with reference to water temperature (40°F) and to the elevation above sea level, the following tables show the drop in hydraulic pressure head in relation to the elevation above sea level, and the suction loss in relation to temperature.

Water Temperature (°C)	68	104	140	176	194	230	248
Suction Loss (ft)	-0.7	2.3	6.6	16.4	24.3	50.5	70.5

Elevation Above Sea Level (ft)	1600	3300	4900	6500	8200	9800
Suction Loss (ft)	1.8	3.6	5.4	7.2	9.0	10.8

To reduce it to a minimum, especially in cases of high suction head (over 13 – 16 feet) or within the operating limits with high flow rates, we recommend using a suction line having a larger diameter than that of the pump's suction port. It is always a good idea to position the pump as close as possible to the liquid to be pumped.

Goulds Pumps

PHV - Packaged Hydrovar Series

TECHNICAL DATA – WATER PROPERTY CHART

Temp °F	Temp °C	Specific Volume (Cubic ft/lb)	Specific Gravity			Weight (lb/cubic ft)	Vapor Pressure (psi Abs)
			@ 39.2°F	@ 60°F	@ 68°F		
32	0.0	0.01602	1.000	1.001	1.002	62.42	0.088
35	1.7	0.01602	1.000	1.001	1.002	62.42	0.100
40	4.4	0.01602	1.000	1.001	1.002	62.42	0.122
50	10.0	0.01603	0.999	1.001	1.002	62.38	0.178
60	15.6	0.01604	0.999	1.000	1.001	62.34	0.256
70	21.1	0.01606	0.998	0.999	1.000	62.27	0.363
80	26.7	0.01608	0.996	0.998	0.999	62.19	0.507
90	32.2	0.0161	0.995	0.996	0.997	62.11	0.698
100	37.8	0.01613	0.993	0.994	0.995	62.00	0.949
120	48.9	0.0162	0.989	0.990	0.991	61.73	1.692
140	60.0	0.01629	0.983	0.985	0.986	61.39	2.889
160	71.1	0.01639	0.977	0.979	0.979	61.01	4.741
180	82.2	0.01651	0.970	0.972	0.973	60.57	7.510
200	93.3	0.01663	0.963	0.964	0.966	60.13	11.526
212	100.0	0.01672	0.958	0.959	0.960	59.81	14.696
220	104.4	0.01677	0.955	0.956	0.957	59.63	17.186
240	115.6	0.01692	0.947	0.948	0.949	59.10	24.97
260	126.7	0.01709	0.938	0.939	0.940	58.51	35.43
280	137.8	0.01726	0.928	0.929	0.930	58.00	49.20
300	148.9	0.01745	0.918	0.919	0.920	57.31	67.01
320	160.0	0.01756	0.908	0.909	0.910	56.66	89.66
340	171.1	0.01787	0.896	0.898	0.899	55.96	118.01
360	182.2	0.01811	0.885	0.886	0.887	55.22	153.04
380	193.3	0.01836	0.873	0.874	0.875	54.47	195.77
400	204.4	0.01864	0.859	0.860	0.862	53.65	247.31
420	215.6	0.01894	0.846	0.847	0.848	52.80	308.83
440	226.7	0.01926	0.832	0.833	0.834	51.92	381.59
460	237.8	0.0196	0.817	0.818	0.819	51.02	466.9
480	248.9	0.02	0.801	0.802	0.803	50.00	566.1
500	260.0	0.0204	0.785	0.786	0.787	49.02	680.8
520	271.1	0.0209	0.765	0.766	0.767	47.85	812.4
540	282.2	0.0215	0.746	0.747	0.748	46.51	962.5
560	293.3	0.0221	0.726	0.727	0.728	45.30	1133.1
580	304.4	0.0228	0.703	0.704	0.704	43.90	1325.8
600	315.6	0.0236	0.678	0.679	0.680	42.30	1542.9
620	326.7	0.0247	0.649	0.650	0.650	40.50	1786.6
640	337.8	0.026	0.617	0.618	0.618	38.50	2059.7
660	348.9	0.0278	0.577	0.577	0.578	36.00	2365.4
680	360.0	0.0305	0.525	0.526	0.527	32.80	2708.1
700	371.1	0.0369	0.434	0.435	0.435	27.10	3093.7

VOLUMETRIC CAPACITY

Litres per minute l/min	Cubic metres per hour m ³ /h	Cubic feet per hour ft ³ /h	Cubic feet per minute ft ³ /min	Imp. gal. per minute Imp. gal./min	US gal. per minute Us gal./min
1,0000	0,0600	2,1189	0,0353	0,2200	0,2640
16,6670	1,0000	35,3147	0,5886	3,6660	4,4030
0,4720	0,0283	1,0000	0,0167	0,1040	0,1250
28,3170	1,6990	60,0000	1,0000	6,2290	7,4800
4,5460	0,2728	9,6326	0,1605	1,0000	1,2010
3,7850	0,2271	8,0209	0,1337	0,8330	1,0000
0,1100	0,0066	0,2339	0,0039	0,0240	0,0290

PRESSURE AND HEAD

Newtons per square metre N/m ²	kilopascal kPa	bar bar	Pound force per square inch psi	metre of water m H ₂ O	millimetre of mercury mm Hg
1,0000	0,0010	1 x 10 ⁵	1,45 x 10 ⁻⁴	1,02 x 10 ⁻⁴	0,0075
1000,0000	1,0000	0,0100	0,1450	0,1020	7,5000
100000,0000	100,0000	1,0000	14,5000	10,2000	750,1000
98067,0000	98,0700	0,9810	14,2200	10,0000	735,6000
6895,0000	6,8950	0,0690	1,0000	0,7030	51,7200
2984,0000	2,9840	0,0300	0,4330	0,3050	22,4200
9789,0000	9,7890	0,0980	1,4200	1,0000	73,4200
133,3000	0,1330	0,0013	0,0190	0,0140	1,0000
3386,0000	3,3860	0,0338	0,4910	0,3450	25,4000

LENGTH

millimetre mm	centimetre cm	metre m	inch in	foot ft	yard yd
1,0000	0,1000	0,0010	0,0394	0,0033	0,0011
10,0000	1,0000	0,0100	0,3937	0,0328	0,0109
1000,0000	100,0000	1,0000	39,3701	3,2808	1,0936
25,4000	2,5400	0,0254	1,0000	0,0833	0,0278
304,8000	30,4800	0,3048	12,0000	1,0000	0,3333
914,4000	91,4400	0,9144	36,0000	3,0000	1,0000

VOLUME

cubic metre m ³	litre litre	millilitre ml	imp. gallon imp. gal.	US gallon US gal.	cubic foot ft ³
1,0000	1000,0000	1 x 10 ⁶	220,0000	264,2000	35,3147
0,0010	1,0000	1000,0000	0,2200	0,2642	0,0353
1 x 10 ⁻⁶	0,0010	1,0000	2,2 x 10 ⁻⁴	2,642 x 10 ⁻⁴	3,53 x 10 ⁻⁵
0,0045	4,5460	4546,0000	1,0000	1,2010	0,1605
0,0038	3,7850	3785,0000	0,8327	1,0000	0,1337
0,0283	28,3170	28317,0000	6,2288	7,4805	1,0000

Goulds Pumps

PHV - Packaged Hydrovar Series

NOTES

NOTES



ITT
2881 East Bayard Street, Seneca Falls, NY 13148
Phone: (315) 568-7123 • Fax: (315) 568-7973
www.goulds.com

Goulds Pumps and G&L are registered trademarks of ITT Corporation. ITT, the Engineered Blocks Symbol and Engineered for Life are registered trademarks of ITT Manufacturing Enterprises, Inc.

Copyright © 2009 ITT Corporation BPHV September, 2009 Printed in U.S.A.
SPECIFICATIONS ARE SUBJECT TO CHANGE WITHOUT NOTICE.

